

manual for:

PRM310

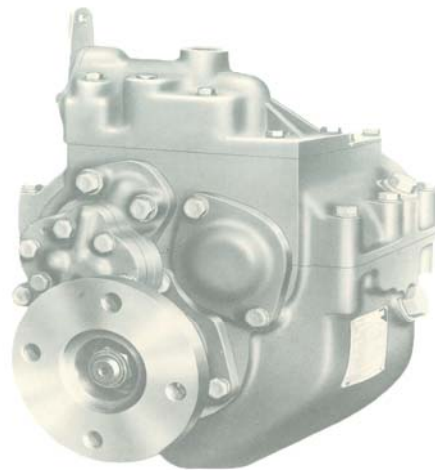

this manual is offered to you by:



DINTRA TRANSMISSIES V.O.F.

Keizerswoert 30 - 3881 LE - Putten - NL

Tel.: +31(0)341-353712 - Fax +31(0)341-360046

www.dintra.com

info@dintra.nl

PRM 310 BY NEWAGE

WORKSHOP MANUAL

NEWAGE

NEWAGE TRANSMISSIONS LIMITED

Barlow Road, Coventry, CV2 2LD, England

Telephone: (0203) 617141 Telex: 31333

A Charterhouse Group Company

Registered in England, Reg. No. 345283

Registered Office: Barlow Road, Coventry, CV2 2LD, England



FOREWORD

The workshop manual has been prepared to assist the operator or user of PRM marine gearboxes and also to enable the skilled service engineer to undertake more detailed maintenance and overhaul.

GENERAL INFORMATION

PRM hydraulic marine gearboxes will give trouble-free service provided they are correctly installed, aligned and maintained. In the event of failure, the engine distributor who supplied the gearbox, or his local dealer, should be informed; where this is not possible, Newage Transmissions Limited, or the distributor for the area, should be notified. In all communications, verbal or otherwise, the model and serial number of the gearbox must be quoted in order to ensure correct identification and supply of parts.

CLAIMS UNDER WARRANTY

Claims for replacement of parts under warranty must always be submitted to the distributor who supplied the gearbox; if this is not possible, application may be made to the nearest distributor or dealer, who must, however, be advised of the supplier's name and address.

SERVICE PARTS

The comprehensive illustrated parts list gives full information and ordering procedures.

NEWAGE TRANSMISSIONS LIMITED

Newage Transmissions Limited 1982

Barlow Road Coventry CV2 2LD England
Telephone 0203 - 617141
Telex 31333 Cables 'Supagears' Coventry

Printed in England

Registered in England, No. 345283

Registered Office: Barlow Road, Coventry, CV2 2LD

A Charterhouse Group Company

PRM 310 SERVICE MANUAL

CONTENTS

1. General Data
 - 1.1 Specifications
 - 1.2 Application data
 - 1.3 Installation details
2. Introduction
3. Construction
 - 3.1 Gear case
 - 3.2 Gear train
 - 3.3 Oil pump
 - 3.4 Valve block
 - 3.5 Neutral safety start switch
4. Operating system
 - 4.1 Output rotations
 - 4.2 Hydraulic system
 - 4.3 Lubrication
 - 4.4 Approved oils
5. Installation
 - 5.1 General
 - 5.2 Checking the flywheel housing
 - 5.3 Checking the flywheel
 - 5.4 Gearbox mounting positions
 - 5.5 Mounting the gearbox to the engine
 - 5.6 Oil cooler
 - 5.7 Alignment to propeller shaft
 - 5.8 Installation angle
 - 5.9 Twin installations
 - 5.10 Remote control operating unit

6. Operation

- 6.1 First-time usage
- 6.2 Drive selection
- 6.3 Trailing (free-wheeling) the propeller
- 6.4 Emergency operation

7. Routine maintenance

- 7.1 Initial maintenance (25 hours running)
- 7.2 Daily checks
- 7.3 Annual checks
- 7.4 Winter storage
- 7.5 Other maintenance operations

8. Fault finding

9. Servicing and repairs

- 9.1 Valve block
- 9.2 Oil pump
- 9.3 Removing transmission from boat
- 9.4 Removing input and layshaft assemblies
- 9.5 Servicing input and layshaft assembly components
 - 9.5.1 Input shaft oil seal
 - 9.5.2 Drive end bearing
 - 9.5.3 Clutch assembly
 - 9.5.4 Clutch gear
 - 9.5.5 Drive pinion
 - 9.5.6 Rear bearings
 - 9.5.7 Piston rings and feeder
- 9.6 Replacing the input and layshaft assemblies
- 9.7 Removing output shaft assembly
- 9.8 Servicing output shaft assembly components
 - 9.8.1. Front bearing and output gear
 - 9.8.2. Rear bearing and oil seal
- 9.9 Reassembling the output shaft
- 9.10 Shimming procedures

10. Tightening torques

11. Identification plate

12. Spare parts list

LIST OF ILLUSTRATIONS – PRM 310 SERVICE MANUAL

- Fig. 1. Gearbox cut-away
- Fig. 2. Internal layout diagram
- Fig. 3. Oil pump mounting – anticlockwise engines
- Fig. 4. Oil pump mounting – clockwise engines
- Fig. 5. Wiring diagram for neutral safety start device
- Fig. 6. Operating lever positions and output rotations
- Fig. 7. Hydraulic and lubricating oil circuits
- Fig. 8. Checking engine flywheel and flywheel housing
- Fig. 9. Gearbox mounting position
- Fig.10. Engine and gearbox cooling circuit
- Fig.11. Propeller rotation, twin installations
- Fig.12. Operating cable entry, twin installations
- Fig.13. Piston ring fitting procedure
- Fig.14. Shimming procedure
- Fig.15. Identification plate.

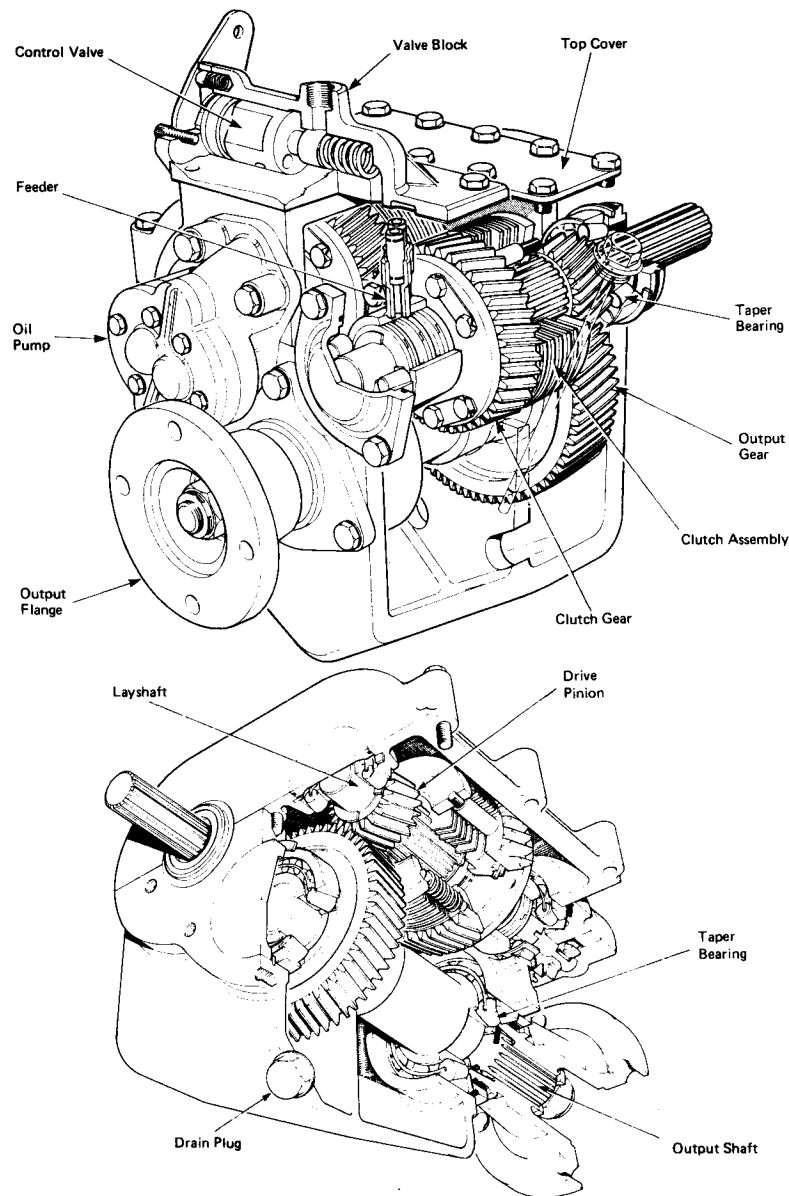

Fig. 1. Gearbox Cut-Away – General Arrangement

1. GENERAL DATA

1.1 Specifications

Power rating: 1:1 up to 6.38 hp (4.76kW) per 100 rev/min
 1.459:1 up to 6.38 hp (4.76kW) per 100 rev/min
 1.96:1 up to 6.38 hp (4.76kW) per 100 rev/min
 2.94:1 up to 6.19 hp (4.62kW) per 100 rev/min

Note: all ratings are for guidance and will vary according to application and duty cycle. Further details available from factory or distributor.

Input speed: Up to 2500 rev/min continuous, 3000 rev/min intermittent.

Input rotation: either hand.

Output rotation: either hand as required.

Gear ratios: 1:1, 1,459:1, 1,96:1 or 2,94:1

Approximate dry weight: PRM310S: 669N (68kg, 150lb).
 PRM 310L: 739N (75kg, 165lb).

Oil capacity: 3.25 litres (5.5 pints)

Working oil pressure: 260lb/in² (1790 kN/mm², 18.3 kg/cm²).

Working oil temperature: 50^o – 80^o; maximum permissible temperature 90^oC.

Transmission cooling: Transmission cooler must be fitted; provision made for connecting unit to operating valve block.

Capacity of cooler required will vary according to ambient temperature, engine horsepower and other factors, but as a general guide a cooler of 7 hp (5.22 kW) capacity and oil flow rate of 25.8 litres

per hour per 1000 rev/min input should be adequate. Suitable coolers are available from the factory.

Engine mounting adaptors:

SAE2, SAE3 and SAE4 flywheel housing adaptor flanges available; mounting pads provided enabling support feet to be fitted if required.

PRM310L incorporates mounting flange to Borg Warner pattern.

Input drive couplings:

Flexible drive couplings for flywheels of 8in, 10in, or 11½in nominal diameter to SAE J620C.

Gearcase:

Heavy duty cast iron constructed in two halves for ease of servicing; ribbed internally for rigidity and strength.

Input shaft:

29mm (1.125in) diameter, SAE10 spline

Propeller thrust:

Ahead and astern thrust carried by output shaft bearings of adequate capacity for all factory approved ratings.

Output flange:

152.4mm (6.0in) diameter, with 6 holes, 13mm (33/64in) diameter on 121mm (4.75in) p.c.d.

Installation angle:

The maximum fore and aft installation angle permissible at rest is 17°.

1.2 Application details

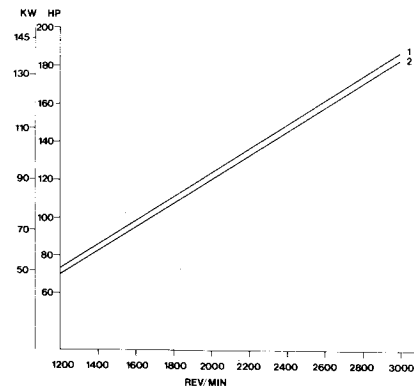

- 1) 1:1, 1.459 and 1.96:1 Ratios.
- 2) 2.94:1 Ratio.

These ratings are for workboats fishing boats and pleasure boats operating less than 1,500 hours per year.

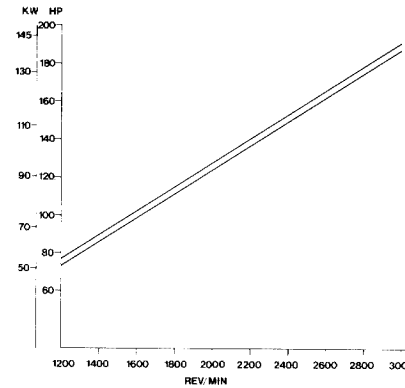

- 1) 1:1, 1.459:1 and 1.96:1 Ratios.
- 2) 2.94:1 Ratio.

These ratings are for pleasure craft and planing craft operating for less than 500 hours per year with full throttle usage less than 10 minutes in any one hour.

NOTE: These ratings have been established in order to ensure the long and trouble-free life of the gearbox.

However, operating conditions can vary widely with consequential effects on the gearbox, and these ratings should be used for general guidance only. If in any doubt, or for particularly arduous duty or for applications outside the powers and speeds shown here, please consult factory or distributor.

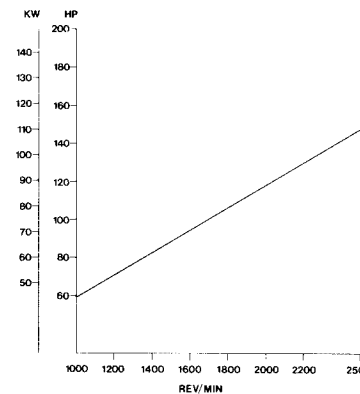

Rating covers all ratios, for workboats operating on a continuous rating for more than 1,500 hours per year.

Classifying Societies

Please refer to factory for details of Classifying Society approvals.

1.3 Installation Details

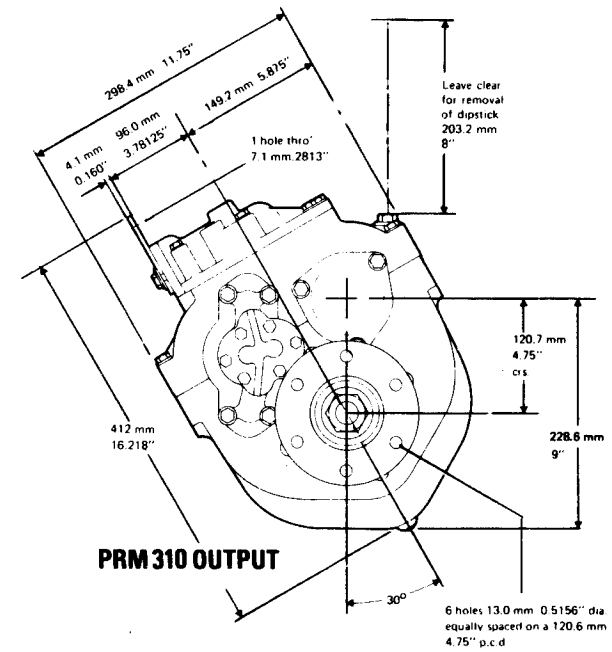
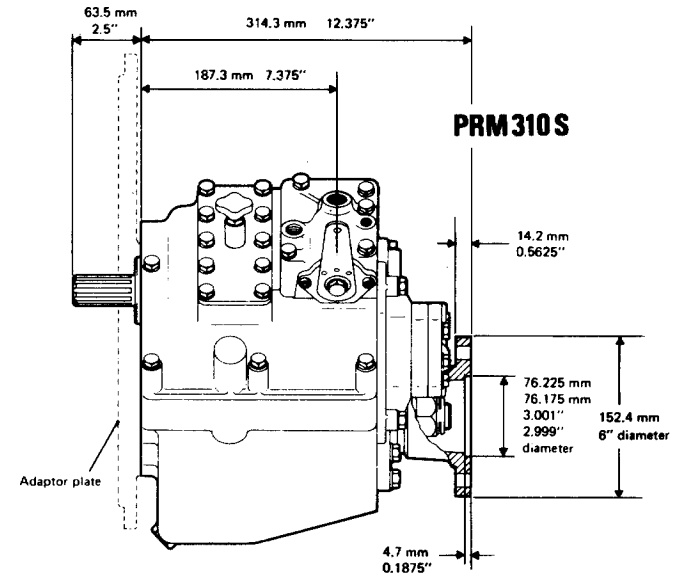
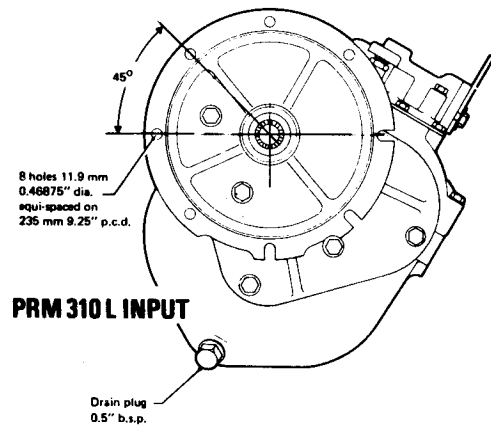
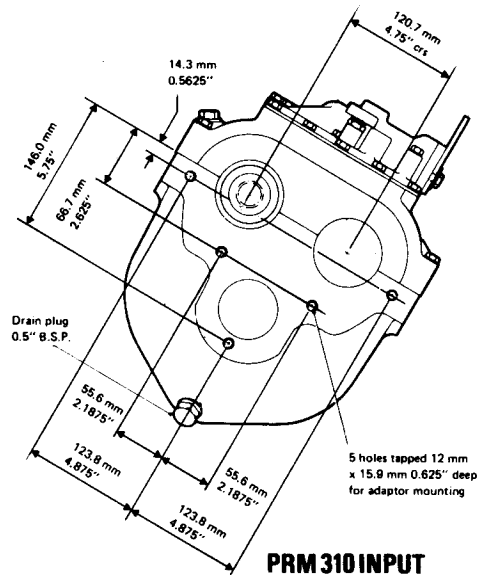

1.3 Installation Details

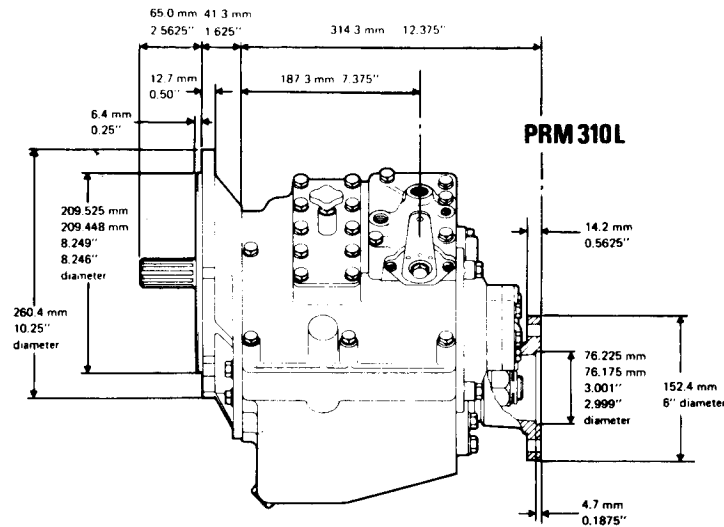

INPUT SHAFT DETAILS

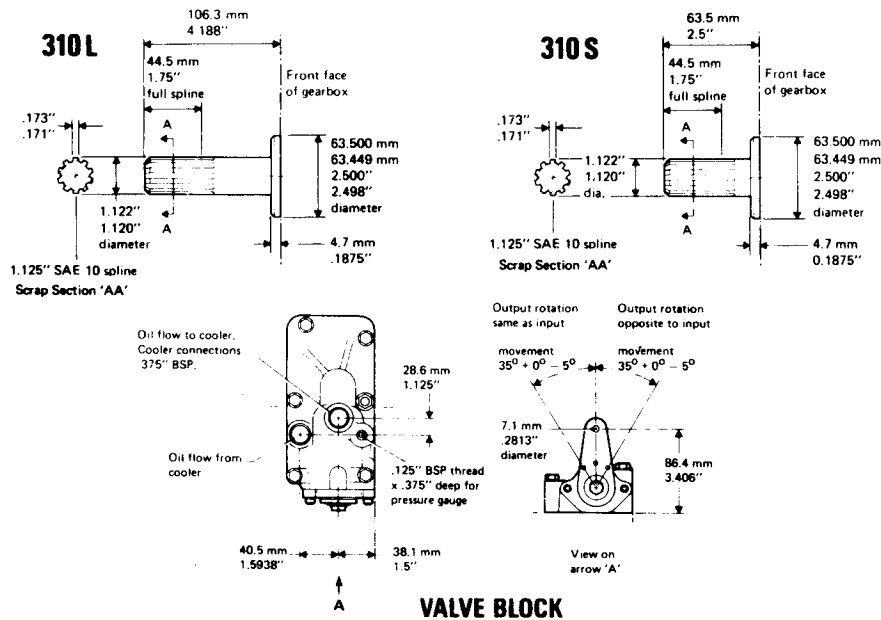

2. INTRODUCTION

PRM marine transmissions are oil-operated gearboxes of the counter-shaft type with separate oil-operated multi-disc clutches (which need no adjustment) for both ahead and astern drive. This design permits full power to be transmitted in astern as well as ahead, and also allows right-hand or left-hand propeller rotation in ahead drive, with identical ratios in ahead and astern.

Both left-hand (anti-clockwise) and right-hand (clockwise) rotating engines can be accommodated.

Note: when describing engine rotations, face the engine on which the transmission is to be mounted and describe the rotation accordingly. Similarly, describe the transmission output rotation as clockwise or anticlockwise as seen when standing behind the gearbox output coupling facing towards the input or engine end of the transmission.

3. CONSTRUCTION

3.1 Gearcase

The gearcase has been kept free from hydraulic pipes, cylinders and associated components, and the only items mounted externally are oil pumps, hydraulic control block and operating lever.

A magnetic drain plug is provided at the front of the gearcase; this can be removed if required to allow suitable pipework to be connected to a hand-operated drain pump.

Connections are provided on the valve block for the oil cooler and pressure gauge.

3.2 Gear train

The transmission comprises an input shaft assembly, a layshaft assembly and an output shaft.

The input shaft, which is supported by a taper roller bearing at either end, incorporates a drive pinion of the required ratio (running on a special self-lubricating bearing), the forward (when used with a right-

hand propeller) drive clutch assembly, the clutch gear and a hydraulically actuated piston to operate the clutch.

The layshaft is similarly supported by taper roller bearings and also incorporates a drive pinion of the same ratio (again running on a special self-lubricating bearing), the reverse (when used with a right-hand propeller) drive clutch assembly, a clutch gear of opposite hand rotation to that on the input shaft, and a hydraulically actuated piston to operate the clutch.

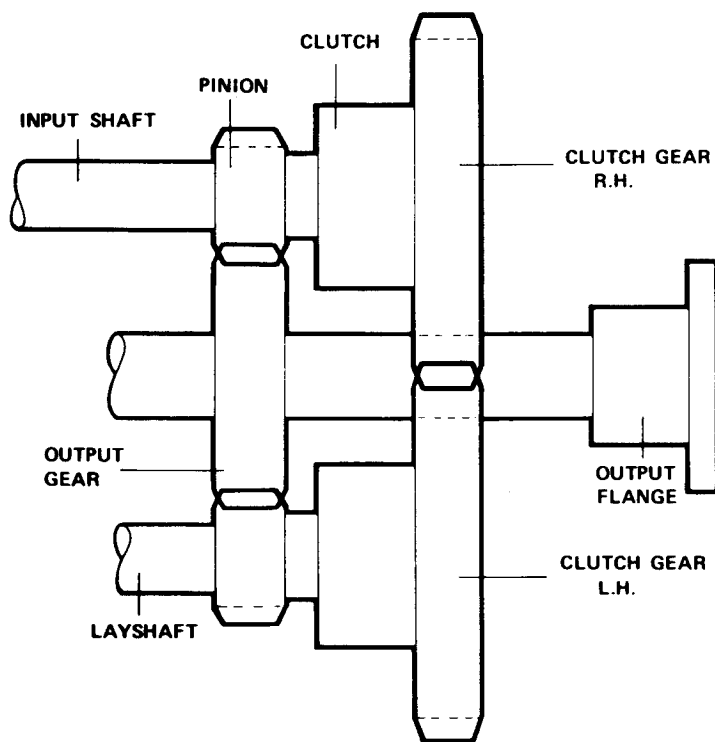

Fig. 2. internal layout

The output shaft runs on amply proportioned bearings, arranged in such a way that propeller thrust can be satisfactorily absorbed; it also carries the output gear and the output flange.

3.3 Oil pump

A cast iron gear-type pump externally mounted at the rear of the gear case and normally driven by the layshaft supplies oil at high pressure for actuation of the clutch assemblies, and at lower pressure for lubrication circuits.

When the transmission is used with anti-clockwise engines the oil pump is mounted in its standard position, whether a right-hand or left-hand propeller is used. If the transmission is used with clockwise engines, the oil pump has to be mounted in a position 180° from the normal.

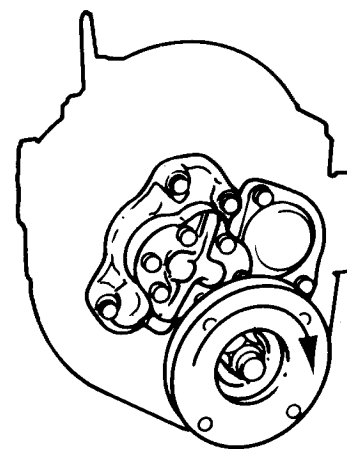

Fig. 3. Oil pump mounting — anti-clockwise engines

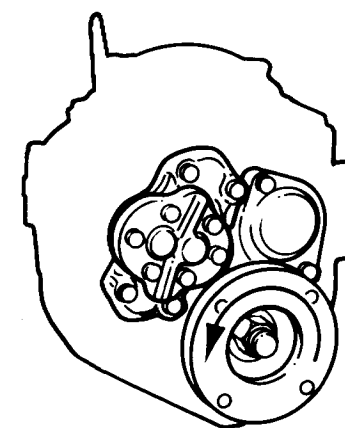

Fig. 4. Oil-pump mounting — clockwise engines

3.4 Valve block

The valve block is located on top of the gear case and contains the main control valve, integral with which is the high pressure valve which controls the supply to the clutch assemblies. Oil which is surplus to clutch operation requirements is used for lubrication purposes.

The control valve is fitted with a spring-loaded neutral detent; this provides a positive neutral position and ensures positive selection of either ahead or astern drive.

3.5 Neutral safety switch

A neutral safety start switch, which ensures that the engine to which the gearbox is fitted cannot be started unless the gearbox is in neutral, is available as an optional extra.

This device is of obvious benefit, since it will help prevent accident or damage caused by a boat moving ahead or astern on engine start-up in a crowded marina or other area.

When used, the switch is located on the valve block (see item C on the parts list) and should be wired into the starter circuit as shown in Fig 5.

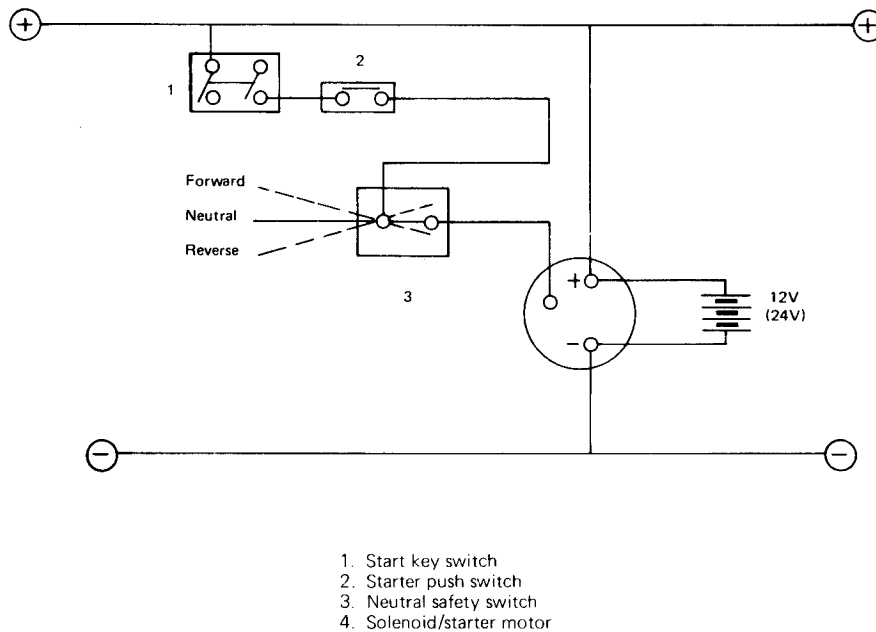

Fig. 5. neutral safety start switch-wiring diagram

4. OPERATING SYSTEM

4.1 Output rotations

With the control lever at the mid-point of travel or neutral position and the engine running, the splined input shaft and the clutch gear rotate at engine speed. The clutch gear is in constant mesh with the clutch gear on the layshaft which is therefore also driven at engine speed, but in the opposite rotation. Since neither clutch is engaged, the drive pinions do not rotate.

When the control lever is moved to the 'ahead' position, the hydraulic system is actuated and oil is directed at high pressure to the clutch on the input shaft; the clutch engages and engine drive is directed to the forward drive pinion. The pinion turns the gear on the output shaft and the propeller shaft and propeller are rotated in the direction corresponding to ahead movement of the vessel.

Similarly, when the control lever is moved to the 'astern' position, the clutch on the layshaft is engaged and drive applied to the reverse pinion. This turns the output shaft gear in the opposite direction; and the propeller shaft and propeller rotate in the direction corresponding to astern movement of the vessel.

Fig. 6 operating lever movements and rotations obtained

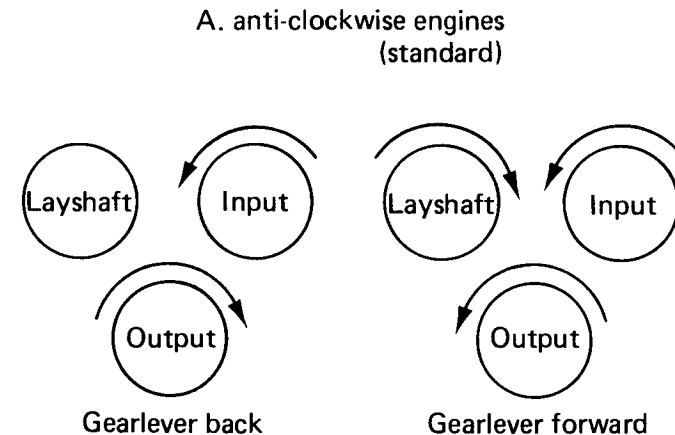

**B. clockwise engines
(uncommon)**

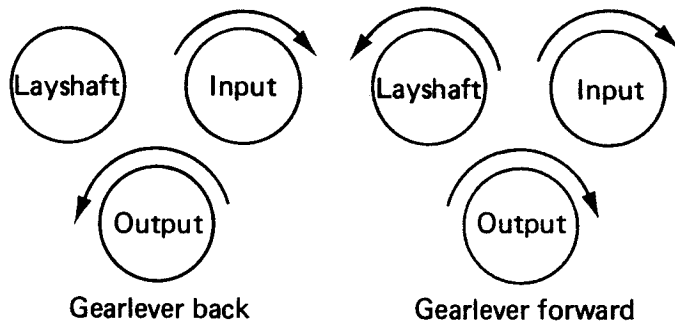

- Note:**
- (i) Rotations are as seen looking from the propeller forward to the gearbox.
 - (ii) Anti-clockwise engines are by far the most common, and the standard gearbox build therefore assumes an anti-clockwise input.

4.2 Hydraulic system

Oil is pumped from the gearbox sump through the internal supply pipe and is delivered to the control block, which incorporates a high pressure valve to ensure that the correct operating pressure is maintained.

When the operating lever is moved, oil is delivered under pressure to a feeder on either the input shaft or layshaft and thence to a piston which actuates the appropriate clutch for either ahead or astern drive. Oil in excess of that required for hydraulic actuation is used for lubricating the gearbox.

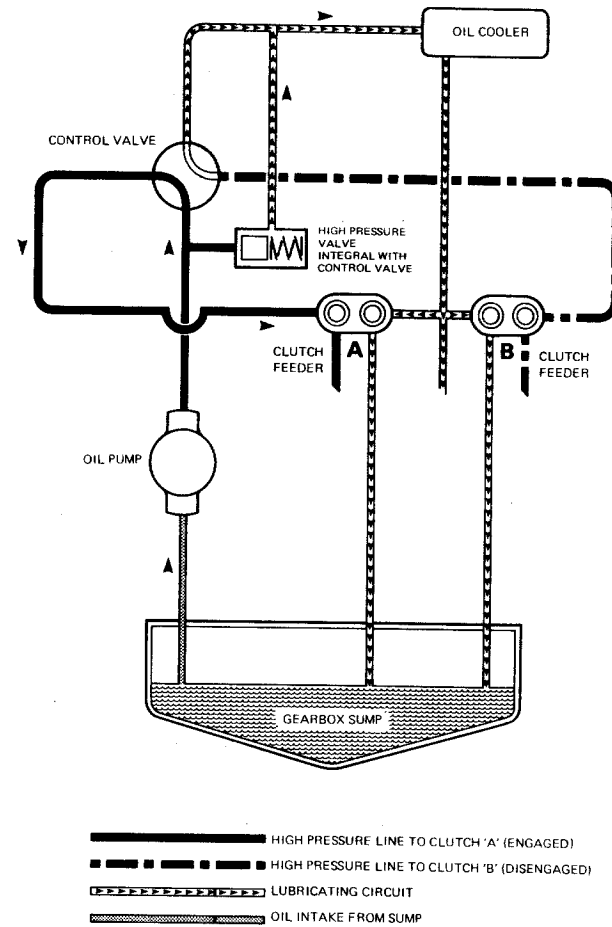

Fig 7. Hydraulic and lubricating oil circuits

4.3 Lubrication

Oil for lubrication purposes is also delivered via the internal supply pipe to the control block. Irrespective of whether ahead or astern is engaged, oil is diverted from the discharge side of the pressure relief valve to an external oil cooler. After passing through the cooler, the oil is directed through channels on the valve block to the feeders and thence through the layshaft and drive shaft to lubricate the clutch assemblies.

4.4 Approved oils

Company	Ambient Temperature Below 0°C	Ambient Temperature 0°C -- 30°C	Ambient Temperature Above 30°C
BP	BP Vanellus M20-50	BP Vanellus M20-50	BP Vanellus M20-50
Castrol	Castrol GTX or Deusol CRB 20W/50	Castrol GTX or Deusol CRB 20W/50	Castrol GTX or Deusol CRB 20W/50
Century	Century Supreme 20W/50 or Centilube Supreme 10W/30	Century Supreme 20W/50 or Centilube Supreme 10W/30	Century Supreme 20W/50
Chevron	Chevron Delo 100 10W or Chevron Delo 200 10W	Chevron Delo 100 20W/20 or Chevron Delo 200 20W/20	Chevron Delo 100 30 or Chevron Delo 200 30
Conoco	Conoco 20W/50 or Conoco HD 10W/30	Conoco 20W/50 or Conoco HD 10W/30	Conoco 20W/50
Duckhams	Fleetol Multilite	Q Motor Oil or Fleetol Multi-V	Q Motor Oil or Fleetal Multi-V
Eif	Cougar 15W/30	Cougar 15W/30	Cougar 15W/30
Esso	Esso Superlube or Essolube HDX Plus 10W-30 or Essolube XD-3 10W	Esso Superlube or Essolube HDX Plus 30 or Tromar HD30	Essolube HDX Plus 30 or Tromar HD30 or Essolube XD-3 30
Fina	Fina Dilano 20 or Fina 20W/50	Fina Dilano 30 or Fina 20W/50	Fina Dilano 40 or Fina 20W/50
Gulf	G.M.O. XHD 10W/30 or G.M.O. XHD 10W	G.M.O. XHD 10W/30 or G.M.O. XHD 20W/20	G.M.O. XHD 10W/30 or G.M.O. XHD 30
Mobil	Mobil Super 15W-50 or Delvac Special 10W-30 or Delvac Super 15W-40	Mobil Super 15W-50 or Delvac Special 10W-30 or Delvac Super 15W 40	Mobil Super 15W-50 or Delvac Special 10W-30 or Delvac Super 15W-40

Company	Ambient Temperature Below 0°C	Ambient Temperature 0°C -- 30°C	Ambient Temperature Above 30°C
Shell	Shell Super Motor Oil or Rotella TX 20W/40	Shell Super Motor Oil or Rotella TX 20W/40	Shell Super Motor Oil or Rotella TX 20W40
Silkolene	Chatsworth 10 Engine Oil or Permavisco 20W650 Engine Oil	Chatsworth 20 Engine Oil or Permavisco 20W/50 Engine Oil	Chatsworth 30 Engine Oil or Permavisco 20W/50 Engine Oil
Texaco	Ursatx 20W-50 or Ursa Extra Duty 20W-40	Ursatex 20W-50 or Ursa Extra Duty 20W-40	Ursatex 20W-50 or Ursa Extra Duty 20W-40
Total	GTS or HD2.M 20W/50	GTS or HD2.M 20W/50	GTS or HD2.M 20W/50
Valvoline	Super HPO 10W or HDS HDM 10W Grades	XLD 15W 50	XLD 15W 50 or All Climate 20W-50

Customers wishing to use any oil not listed above should send the relevant details to Newage for prior approval. Failure to do so may result in the forfeiture of warranty cover since no claims under warranty will be entertained if oil of the wrong specification is used.

5. INSTALLATION

5.1 General

Drive is usually transmitted from the engine to the gearbox by means of a flexible input coupling which bolts to the engine flywheel with the gearbox input shaft inserted into its centre.

These components enjoy a degree of torsional flexibility, the purpose of which is to damp down engine torsional or cyclic vibrations and prevent them being passed to the transmission, provided that they are correctly fitted.

The strongest engine vibrations are usually those caused by firing in the cylinders; diesel engines, which have high compression ratios, usually generate stronger vibration pulses than petrol (gasolene) engines; and it is often the case that of two engines of roughly equivalent size, the one having the greater number of cylinders will tend to run more smoothly than the one with fewer cylinders, although this is by no means always the case.

In all marine installations, correct alignment is of the utmost importance — misalignment can cause noise, vibration and premature failure — and we strongly recommend that all the procedures detailed in this manual are carefully followed.

5.2 Checking the engine flywheel housing

Attach a dial test indicator, calibrated in units of 0.001 in (0.025mm) or smaller, to the flywheel so that the measuring stylus of the indicator is perpendicular to the bore of the flywheel housing (item A on Fig. 8). Rotate the flywheel and check the deviation on the indicator over one complete revolution: this should not exceed 0.006 in (0.152mm) total indicator reading.

With the dial test indicator still attached to the flywheel, re-position the stylus so that it is perpendicular to the face of the flywheel housing (item B on Fig. 8). Rotate the flywheel and check the deviation over one complete revolution; again, this should not exceed 0.006 in (0.152mm) total indicator reading.

5.3 Checking the engine flywheel

Attach a dial test indicator, calibrated to 0.001 in (0.025mm) or

less, to the engine flywheel housing so that the measuring stylus of the indicator is perpendicular to the bore of the register in the flywheel (item C on Fig. 8). Rotate the flywheel through one complete revolution and note the deviation: this should not exceed 0.005 in (0.125mm) total indicator reading.

With the dial test indicator still attached to the flywheel housing, re-position the stylus so that it is perpendicular to the face of the flywheel register (D on Fig. 8). Rotate the flywheel through one complete revolution and note the deviation; this should not exceed 0.005 in (0.125mm) total indicator reading.

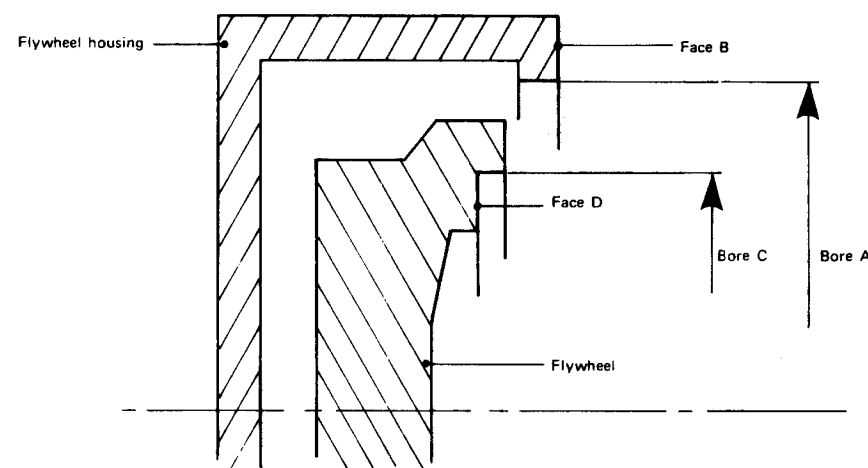
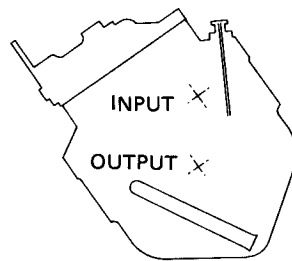

Fig. 8.

5.4 Gearbox mounting positions

In its standard form, the PRM310 is so assembled that the input shaft is the right-hand of the two shafts (looking on the rear of the gearcase from behind).

In order to provide a vertical offset between input and output shaft centres, the gearbox is mounted to the engine tilted at an angle to port; this is the standard mounting position and is referred to as VR mounting. Unless we are specifically notified to the contrary when orders are placed all gearboxes are automatically built for VR mounting.



RIGHT HAND MOUNTING
VERTICAL (VR)

Fig. 9. gearbox mounting position.

5.5 Mounting the gearbox to the engine

PRM 310S

1. Mount the flexible input coupling to the flywheel, using an alignment mandrel if available, and bolt it to the flywheel using the holes provided. Where components to SAE standard are used, the outside diameter of the drive plate or coupling should be a close fit in the register on the flywheel.

If a mandrel is not available, tighten the mounting bolts, just sufficiently to prevent free movement, assemble the gearbox to the coupling, and rotate the engine two or three revolutions by hand to align the plate. Tighten up two or three opposite bolts, using the inspection window provided on the gearbox adaptor flange.

2. Remove the gearbox and fully tighten the flexible input coupling bolts.
3. Taking care to ensure correct alignment, mount the adaptor flange to the front of the gearbox.

4. Offer up the gearbox and adaptor to the input coupling and engine flywheel housing at the correct angle of inclination to obtain the shaft offset and insert the gearbox input shaft into the centre of the coupling (it may be necessary to rock the shaft slightly to ensure that the shaft enters). Press the assembly fully into position, align the mounting holes in the adaptor flange with those on the flywheel housing and bolt securely.

PRM310L

Procedure for mounting these versions to the engine are exactly as given above, except that the adaptor flange is fitted to the gearbox at the factory.

5.6 Oil cooler

All PRM310 gearboxes must be fitted with an oil cooler to maintain correct working temperatures. To permit a suitable cooler to be fitted, two 3/8in BSP connections are provided on the valve block, and these are blanked off with "Redcap" seals on delivery from the factory.

Remove the "Redcap" seals and connect via suitable hoses to the inlet and outlet connections on the cooler, which is then connected up to the cooling system on the engine. The cooler may be mounted on any convenient location; the adaptor flange or bulkhead of the boat are popular locations.

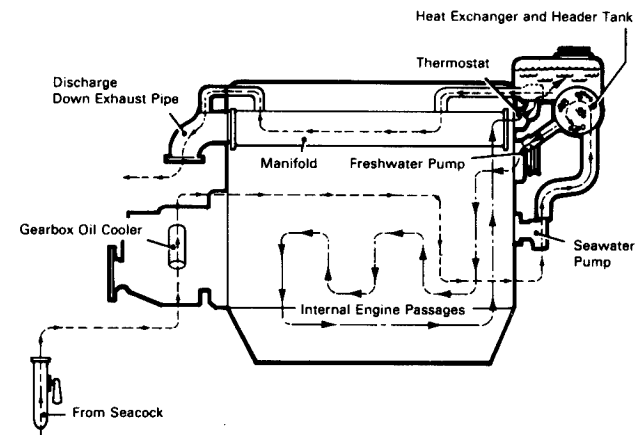

Fig. 10. gearbox and engine cooling circuit

5.7 Alignment to propeller shaft

Alignment between the propeller shaft flange and the mating flange on the gearbox output flange is extremely important since excessive vibration and stress leading to damage and perhaps even failure can occur if correct alignment is not achieved.

The decision as to whether a flexible or a rigid propshaft coupling will be used will vary from boat to boat, although many people consider it preferable to use a rigid coupling, particularly in those boats whose hulls have sufficient rigidity not to allow flexing in heavy sea conditions, which would cause a shift of the engine and transmission relative to the propshaft.

Two of the main conditions where a flexible coupling should be used are:

- (a) in boats whose hulls are not sufficiently rigid to prevent the flexing referred to above.
- (b) in cases where the engine is mounted on flexible mounts.

In both cases, the flexible coupling will isolate engine vibration or other movement from the propshaft, thereby helping maintain correct alignment of the propshaft and stern tube.

It must be stressed that flexible couplings are not designed to take up misalignment, and whether a solid or a flexible coupling is used it is extremely important that the following points are carefully checked:

- (i) the coupling should be a tight press fit on the shaft and the keyway accurately machined to the correct size;
- (ii) the two halves of the coupling must be carefully aligned. This should be done by bringing the two flanges sufficiently close together that a feeler gauge can be inserted to check the vertical and horizontal alignment. Since the propeller shaft line is normally fixed in the boat, alignment is usually achieved by adjusting engine mount shims, or the engine mounts themselves.

Note: whenever possible the engine and gearbox should be installed whilst the boat is in the water, otherwise there is a danger of the hull distorting due to insufficient support being provided over a large enough surface area. If the engine and transmission are fitted before the hull is placed

in the water, the whole installation should be very carefully re-checked for alignment after launching.

5.8 Installation angle

The transmission should normally be installed so that the maximum fore and aft angle relative to the waterline does not exceed 17° with the boat at rest. Please consult the factory if installation angles greater than this are required.

5.9 Twin Installation

The rotation of a propeller, even in a single engine installation, tends to have a slight "turning" effect on the handling of the boat, but this can normally be corrected with very slight adjustments on the rudder.

In twin installations, the turning effect on the handling of the boat will be much more pronounced if both propellers rotate in the same direction. It is therefore desirable that "handed" (i.e. counter-rotating) propellers be fitted, and it is for this reason that PRM gearboxes are capable of providing either hand of output rotation at any of the available gear ratios.

It is also preferable for the starboard (right-hand) propeller to rotate clockwise and the port (left-hand) anticlockwise rather than the other way about since in the latter case, when the propeller blades are at the lowest point of their rotational arc they tend to create a vacuum which affects the other propeller by reducing the flow of water to it; furthermore, when the boat is making a tight turn with one gearbox in "ahead" and the other in "astern", the thrust side of one propeller will be acting diametrically opposite to the other one, causing the boat to be deflected off line and thus delaying completion of the manoeuvre.

When connecting remote control units for twin engine/gearbox installations, it should be remembered that forward operation of the gearbox operating lever will produce output rotation as engine (generally left-hand, or anticlockwise).

Therefore, in order to provide counter-rotation of the two propeller shafts in the correct direction for 'ahead' drive, with both the remote control operating levers in the 'ahead' position, the operating controls should be fitted so that the cable to the starboard gearbox moves the operating lever back, to provide right-hand rotation.

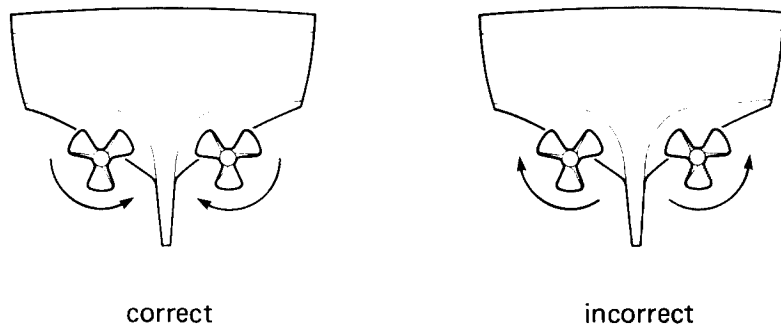

Fig. 11. propeller rotation - twin installations

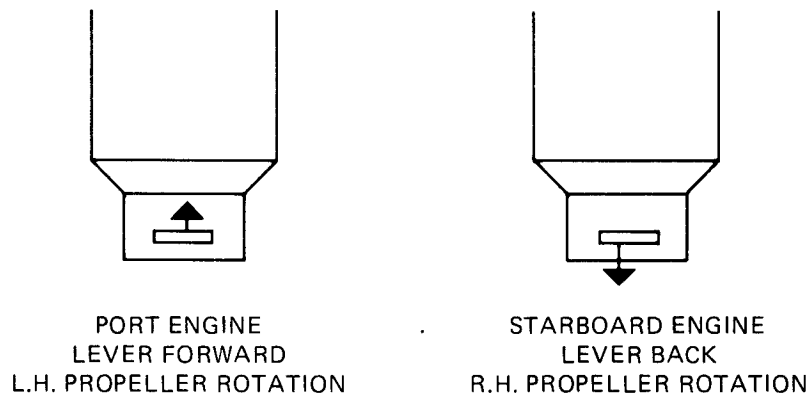

Fig. 12. operating lever movement for ahead drive, twin installations

5.10 Remote control operating systems

All PRM gearboxes can be used with remote control operating systems and indeed the use of the single lever type of remote control, which links the engine throttle to the gearbox operating lever, is highly recommended.

The following points should be noted:

- (i) The gearbox operating lever is provided with a positive neutral position, which greatly assists the setting up of the remote control unit.
- (ii) care should be taken to ensure that the cable moves the gearbox operating lever approximately 1/16" (2mm) short of its maximum forward or backward travel to prevent the lever being brought hard up against the end stop with every gear shift.

The control equipment should in all cases be connected in accordance with the manufacturer's recommendations.

6. OPERATION

6.1 First-time usage

Before starting the engines the following operations should be carried out:-

- (i) fill the gearbox with one of the recommended oils (see section 8) to the maximum level indicated on the dipstick (see section 1.1 for capacity).
- (ii) ensure that the gearbox is in neutral (it is also recommended that a neutral safety start device should be wired into the starter circuit as described in section 3.5).

6.2 Drive selection

The PRM 310 gearbox has been designed and tested to ensure that shifts from "ahead" to "astern" can in emergencies be carried out at any engine speed up to the maximum recommended, and the gearbox will respond extremely rapidly in these circumstances.

However, full-power reversals do place an abnormal if short-lived loading on the gearbox, and transmission life will be increased if

engine speed is brought down to approximately 1,000 rev/min when changing direction; it is for this reason that we recommend the fitment of a proprietary single-lever remote control operating system which links the engine throttle control to the gearbox operating lever.

6.3 Trailing (free-wheeling) the propeller

PRM gearboxes are designed and tested to ensure that prolonged trailing (free-wheeling) of the propeller is permissible for long periods without any detrimental effect on the transmission; this makes them very well suited for use in auxiliary sailboats, motor sailers and multi-engine installations which may be used with one or more engines shut down.

It is not therefore necessary to provide any propeller shaft locking device to protect the transmission, although in the case of racing yachts and other high performance sailboats fitted with two-bladed propellers it may be desirable to fit a propshaft lock so that the propeller can be locked behind the deadwood to reduce drag.

Where propellers are allowed to free-wheel they can be a useful source of free auxiliary power; if a flat pulley is fitted to the propeller shaft a small generator can be belt-driven for charging batteries (although care must be taken not to apply excessive side-load, which could cause vibration and misalignment).

6.4 Emergency operation

Included as standard in every PRM 310 is a device which allows the gearbox to be locked mechanically in 'ahead' drive in the unlikely event of hydraulic failure occurring.

To operate this "get-you-home" device simply remove the top cover (located behind the valve control block on top of the gearbox and fastened with ten bolts). Attached to the underside of the cover is a fork which sits over one of the shafts. At the point where the fork sits over the shaft is a splined ring. Move this ring away from the engine and engage it fully into the mating spline in the clutch end cover (until it disappears from view). Replace the top cover. The fork should sit over the same shaft as when removed and will stop the splined ring from moving out of engagement whilst running. Replace the ten bolts retaining the top cover.

Select neutral on the operating lever and disconnect the operating cable. The engine can now be run; we recommend a maximum of one third full throttle in order to avoid possible damage to the transmission. Check that there is still enough oil in the gearbox for lubrication purposes.

- (A) When the emergency drive is in use, neither astern drive nor neutral can be selected and there will be no means of stopping the boat; other than stopping the engine.
- (B) After emergency drive has been used, qualified assistance should be sought to give the transmission a thorough check before the gearbox is used again;
- (C) Always disconnect the operating cable and ensure that the gearbox operating lever is in neutral before using the gearbox in emergency drive.
- (D) Never use the top cover for topping-up with oil.

7. ROUTINE MAINTENANCE

7.1 Initial maintenance (after 25 hours running)

Drain all oil from the transmission and refill with one of the recommended lubricants to the high level mark on the dipstick. Operate the engine and gearbox, allowing the oil to circulate; stop the engine and re-check the oil after the oil has settled.

7.2 Daily check

- (i) Check gearbox oil level.
- (ii) make a quick visual inspection of the general condition of the transmission and check for oil leakage especially at the output shaft oil seal and at gasket sealing surfaces.
- (iii) listen for any unusual noises and check their cause.

7.3 Annual checks

- (i) Check all oil cooler hoses and connections for leakage.
- (ii) Check propeller shaft alignment.

- (iii) Check that the remote control operating linkage is accurately adjusted to give the correct amount of travel on the gearbox operating lever.

7.4 Winter storage

Drain water from the transmission oil cooler to avoid freezing or the collection of harmful deposits.

7.5 Other maintenance operations

- (i) The gearbox oil should be changed at periods which roughly correspond to the intervals at which engine oil changes are carried out.
- (ii) The oil should also be changed if it has been contaminated by water, or if the gearbox has suffered major mechanical damage.

8. FAULT FINDING

The fault finding chart below is designed to help diagnose some of the problems which might be encountered. It assumes that the installation and operating instructions in this manual have been followed and we advise that these are checked before proceeding to fault finding.

To avoid prejudicing warranty rights, no repair or other work should be done on the gearbox during the warranty period without first contacting NEWAGE TRANSMISSIONS LTD., COVENTRY, or an authorised distributor or dealer, for advice.

Low oil pressure to both clutches	Propeller speed does not increase with engine speed ahead and astern	Damaged or worn oil pump	Repair with kit or replace.
		Remote control cable or linkage not allowing F-N-R lever to move correct distance	Remove cable and operate lever by hand. Adjust cable if necessary.
		Pressure relief valve spring defective	Remove valve block and replace spring.
Low oil pressure to one clutch	Propeller speed does not increase with engine speed in one direction only.	Piston rings worn. Feeder worn	Remove appropriate clutch shaft. Replace worn feeder or piston rings.
		Damaged 'O' ring in hydraulic circuit	Check 'O' rings in feeder connectors and piston.
		Blocked hydraulic passage in valve block	Remove valve block and examine.
		Damaged clutch plates	Remove and examine clutch on appropriate shaft and replace if necessary.
Gearbox noise	Excessive noise from gearbox	Input coupling defective	Remove, examine and replace if necessary.
		Gear rattle at low speed	Increase engine idling speed.
		Propeller shaft misalignment	Check the alignment of the propeller shaft coupling (see section 5.7); if necessary rectify by adjusting the shims under the engine mounts or the engine mounts themselves.
		Out-of-balance propeller	Remove the propeller and check that the pitch, weight, diameter and balance of all the blades are equal and rectify if necessary.
		Engine/gearbox misalignment	Remove the transmission and check that the flywheel face is flat and that the drive plate or flexible input coupling is correctly aligned.

SYMPTOM	NOTICEABLE EFFECT	CAUSE	REMEDY
No oil pressure	No drive ahead or astern	Damaged oil pump	Remove oil pump and examine. If possible replace gears and shafts with repair kit. If body damaged replace complete unit.
		Broken input drive plate.	Replace drive plate.
Loss of Drive		Oil leaks	Check for evidence of leakage and rectify

SYMPTOM	NOTICEABLE EFFECT	CAUSE	REMEDY
Gearbox noise	Excessive noise from gearbox	Defective bearing	Isolate defective bearing noise, remove and replace.
Excessively high oil temperature	Gearcase too hot to touch	Defective oil cooler	Replace oil cooler.
		Defective pressure relief valve	Remove and examine relief valve. Replace if necessary.
Gearbox oil consumption excessive	Oil level requiring constant topping up	Defective oil seal, gasket or 'O' ring	Clean the outside of the gearcase, particularly around the ends of shafts including the output shaft. Run the engine and observe the gearbox for leaks. Replace seals as required.
		Defective oil cooler	Check for traces of water in the gearbox oil or oil in the cooling water system. Replace cooler if necessary.
		Escape of high pressure in gearbox when dipstick is removed	Defective breather (causing leaks past oil seals)
Control lever on valve block stiff	Difficult to move single lever control	Defective valve or detent spring	Contact distributor or factory for advice.

9. SERVICING AND REPAIRS

The servicing, repair and replacement of components and assemblies on the input shaft and layshaft is made simple by the fact that the gearcase is constructed in two separate halves, the top half being easily removable to give access to the two top shafts.

This can be further simplified by fitting complete replacement shaft assemblies, and where skilled service personnel or reasonable workshop facilities are not readily available, or where time and labour costs are of greatest importance, it may be found advantageous to adopt this procedure.

A cutaway drawing showing the general arrangement of the gearbox is shown in fig. 1 and exploded views of all internal components are contained in the parts list. Many servicing operations can be carried out with the gearbox still mounted to the engine (provided, of course, that there is sufficient space in the engine compartment to allow this); examples are the replacement or repair of valve block and oil pump. It may also be possible to work on the layshaft and even the input shaft. The repair and maintenance of items on the output shaft will require that the gearbox is removed from the boat.

N.B. The input shaft and layshaft are supported by taper roller bearings. It will be necessary to recalculate the number of shims required to correctly load the bearings each time a shaft is stripped for component repair or replacement. Shimming procedure is described in Section 9.10.

9.1 Valve block

The complete valve block is easily removed for inspection and servicing with the gearbox still installed in the boat.

1. Disconnect the oil cooler pipes and the control cable or cables from the lever on the control equipment.
2. Disconnect the wiring from the neutral switch — if fitted.
3. Remove the 5 bolts and one nut which fix the valve block to the gearcase.

To remove the control valve and high pressure valve, simply remove the two cap screws (item no. C6) and withdraw the

valves from the valve body. Care should be taken not to lose the detent ball and springs.

Inspect the O ring (item no. C8) and bearing (item no. C10): replace if worn, damaged or defective. Check that the pressure relief valve spring (item no. C 14) has retained its correct free length (37.2mm, 1.463ins) and if not, replace.

To assemble and refit the valve blocks, simply reverse the above procedure.

9.2 Oil pump

The oil pump assembly can also be easily removed with the gearbox in situ.

1. Note the mounting position of the pump (for refitting).
2. Remove the four bolts securing the oil pump to the main case and withdraw the pump assembly complete with O Rings and shims.
3. Inspect O rings and replace if necessary. If in good condition carefully store until required for refitting.

The pump can now be stripped by removing the 4 fixing bolts in the cover plate. The assembly splits into its three component parts exposing the body, gears and shafts.

If the pump body is damaged, the complete pump assembly (item No. B) must be replaced. If the pump body is in good condition, the oil pump can be repaired using the pump repair kit (items No. B4 to No. B8 inclusive).

N.B. The clutch shaft must be reshimmed if a replacement pump body or complete pump assembly is fitted. If the old pump casing is re-used, refitting the original shims will be adequate.

9.3 Removing the transmission from the boat

1. Ensure that the gearbox operating lever is in the neutral position and disconnect the operating cable or cables.
2. Drain the gearbox oil into a suitable container and disconnect oil cooler pipes.

3. Unscrew and withdraw the bolts connecting the gearbox output flange from the flexible coupling or mating half coupling on the propeller shaft.
4. Sling ropes around the gearbox to provide support while it is being removed from the engine.
5. Unscrew and withdraw the bolts securing the adaptor flange to the engine flywheel housing.
6. Slacken the bolts which secure the input coupling to the flywheel.
7. Withdraw the gearbox, if necessary by rocking the unit slightly in order to disengage the input shaft spline from the opposing spline in the coupling.

9.4 Removing the input shaft and layshaft assembly

To remove with the gearbox still installed in the boat, proceed as follows:-

1. Drain the gearbox oil into a suitable container;
2. Disconnect oil cooler pipes, and the cable from the control lever;
3. Remove the 4 bolts securing the oil pump to the gearcase and remove the pump.
4. Remove the two bolts securing the drive shaft end plate.
5. Unscrew the nut on the valve block and remove the 7 bolts that secure the top half of the gearcase to the lower half. Lift off the top half complete with the valve block assembly and top cover.
6. Slacken the bolts securing the input coupling to the flywheel to allow slight movement. Withdraw the input shaft spline. (On units incorporating 3:1 ratio it is recommended that all bolts but one be removed so that the coupling will pivot on the remaining bolt to permit the input shaft to be lifted with the gearbox case).
7. Lift the input shaft, if necessary rotating slightly so that the spline can be withdrawn from the flexible coupling.
8. Once the spline is cleared, lift the complete shaft assembly from the casing. Lift and remove the layshaft and front cover from the casing.

9.5 Servicing input shaft and layshaft assembly components

9.5.1

Input clutch shaft oil seal.

In the event of an oil leak due to a damaged seal, remove the input end housing from the shaft and force the seal from the housing with the aid of a hardwood drift.

Fit a new oil seal (item no. D27) in the housing and replace the housing.

9.5.2

Drive End Bearing

To renew a damaged or worn bearing proceed as follows:-

1. Support the shaft in a vice, and remove input housing and seal assembly.
2. The bearing outer race will be loose; remove and discard.
3. Withdraw the clutch pinion, spacer and bearing by means of pulley extractors with the jaws of the extractors positioned behind the pinion.
4. Refit the pinion to the shaft.
5. Replace the pinion spacer and locate a new bearing (item no. D2) on the shaft and either handpress or gently drive the bearing into position using a hardwood drift and hammer.
6. Fit the outer race from the replacement taper roller bearing.
7. Re position the end housing, complete with oil seal, O ring and large circlip, on the shaft (first check that the O ring and circlip are in good condition and replace if necessary).

9.5.3

Clutch assembly

Clutch plates which are discoloured by overheating or worn down to the extent that they have lost their criss cross pattern of grooves, will tend to slip. If either of these conditions occurs it is recommended that the entire clutch assembly is replaced as

follows:-

1. Remove the drive pinion bearing as previously described.
2. Unlock and remove the 3 clutch assembly bolts.
3. Withdraw the complete clutch from the shaft.
4. Stand the shaft in an upright position and re-position the assembly bolts through the clutch gear.
5. Fit the clutch end plate (item no. D7) into the clutch gear and then, starting with one of the driver clutch plates (item no. D8), build up the replacement clutch onto the end plate.
6. Replace the pull-off springs over the assembly bolts.
7. Replace the end cover onto the clutch pack, and lightly tighten the assembly bolts.
8. Turn the shaft upside down and tighten the bolts with a torque spanner set at 12.2 Nm (9lbf.ft, 1.24 Kgm) and close the locking strip tabs over the bolt heads.
9. Replace the drive pinion, (first ensuring that the splined ring is fitted where appropriate) into the clutch until it touches the bottom washer.
10. Place the spacer and bearing inner cone onto the shaft and gently drive the bearing into position.

N.B. For shimming procedures please refer to section 9.10.

9.5.4

Clutch gear

To fit a new clutch gear (item no. D18) first remove the clutch as described, then extract the piston retaining spacer and circlips, to allow the piston and clutch gear to be removed from the shaft. (All 15 clutch bolts will need to be taken out before the clutch gear can be removed). Separate the gear from the piston, check that the inner and outer piston ring step joints are intact, and fit a new gear around the piston. Refit the piston to the shaft replacing the circlip and spacer, and reassemble the clutch drive pinion and bearing as previously described.

N.B. It is advisable to renew both clutch gears simultaneously since damage to one will often result to damage to its

mating gear.

9.5.5

Drive pinion

As with the clutch gears it is advisable to renew both drive pinions simultaneously. To ensure that the drive pinion of the correct ratio is used please refer to the parts list at the back of this manual. If it is required to fit a ratio which is different to that which was originally supplied, the output gear as well as both pinions will need to be changed.

To replace the drive pinion, follow the procedure set out in section 9.5.2

N.B. Before refitting the drive pinions the emergency drive splined ring (item no. D6) should be examined and replaced if worn.

9.5.6

Non drive end bearing

Withdraw sufficient clutch securing bolts to permit light bearing pullers to be located behind the feeder, and pull off the bearing. Before refitting, examine the bearing carefully and replace it if it exhibits any sign of damage.

9.5.7

Piston rings and feeder.

Excessive wear or damage may necessitate replacement of the piston rings and feeder in the following manner:-

1. Remove the non drive end bearing as described and remove the feeder and spacer.
2. Remove the piston rings from the shaft with the aid of a special piston ring extractor or a piece of thin steel. Raise one end of the top ring out of the groove and insert the steel strip between the ring and the shaft. Rotate the strip around the shaft applying slight forward pressure to the raised portion of the ring and until it rests on the land above the groove, where it can be eased off. Repeat this

with the other two rings.

3. Take out the new rings from the packing and clean off any grease or inhibitor.
4. If a ring loading tool is available, fit this around the shaft, load the rings onto the tool and locate in their approximate position. Gently withdraw the tool and allow the rings to locate in their respective grooves.
5. Where a loading tool is not available use a thin metal strip, long enough to lay along the shaft above the grooves. Expand each ring just sufficiently to allow it to be placed in its approximate position over the strip. Gently withdraw the strip and locate the rings in their respective grooves. (see fig. 13).
6. Compress each ring in turn and carefully fit the new feeders and spacers.

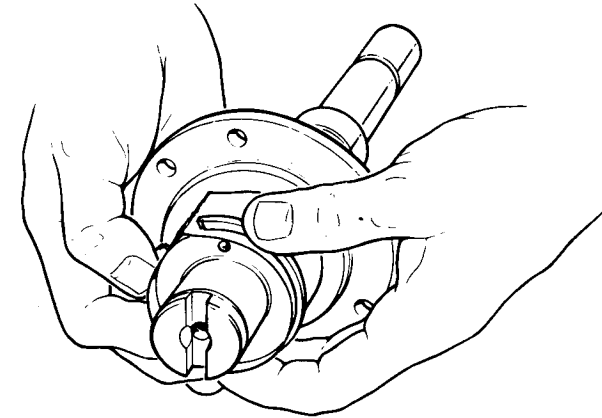

Fig. 13. piston ring fitting procedure.

9.6 Replacing the input shaft and layshaft assemblies.

1. Position the input shaft assembly in the gearcase and ensure that the circlip is correctly located in the lower half of the gearcase, and that the end housing is in position. If the gearbox is still mounted to the engine, engage the input shaft into the spline centre of the drive plate or input coupling.
2. Position the layshaft in the casing ensuring that the end cover is correctly located.
3. Ensure that the top and bottom mating faces for the two gearcase halves are clean and free of any metal burrs. Smear the bottom half case with a liquid gasket compound, fit the top half and secure with 7 bolts and one nut on the valve block.
4. Calculate the number of shims required and locate the correct number in the input shaft end cover.
5. Refit the input shaft end cover, replacing the O ring if damaged.
6. Calculate the number of shims required and locate in the recess provided on the oil pump adaptor.
7. Refit the oil pump, replacing the O ring if damaged.
8. Tighten the bolts securing the drive plate or input coupling to the engine flywheel.
9. If the gearbox has been removed from the engine re-align and reconnect the propeller shaft coupling, oil cooler and operating system as described in sections 5.6, 5.7 and 5.10 (installation).

For shimming details please see section 9.10.

9.7 Removing output shaft assembly

Removal of the output shaft necessitates the gearbox being taken out of the boat (see section 9.3). Then proceed as follows:-

- (i) Remove input shaft and layshaft assemblies (see section 9.4).
- (ii) Remove output shaft end cover by applying a magnet and lightly tapping the gearcase with a soft hammer. If the end cover is corroded in the bore and cannot be removed, it must be drilled to provide extractor holes (necessitating the fitment of a new cover).

- (iii) Remove the two retaining bolts (item no. F3) holding the bearing retaining plate.
- (iv) Remove the four retaining bolts (item no. F19) from the rear oil seal housing.
- (v) Turn the gearcase on end with the output coupling face down. Using a hardwood drift and hammer knock the end of the shaft through the bearing and remove the output shaft assembly from the case. The output gear, front bearing and spacers will now be left inside the case.

9.8 Servicing output shaft assembly components

9.8.1 Front bearing and output gear

- (i) Having removed the output shaft assembly from the gearbox (as described in 9.7) the output gear will be left loose inside the gearcase. Remove the large circlip from the front bearing bore. The front bearing must be carefully removed from its bore using a press or a hardwood drift and hammer.
- (ii) If the bearing is defective check that the gear has not been damaged by debris. Similarly, if the gear is defective, check that the bearing is undamaged.
- (iii) Refit the circlip (item no. F7) on the front bore.
- (iv) For a new gear or front bearing to be fitted, align the output gear and spacer in the gearcase and press the shaft assembly through the rear bore, picking up first the spacer then the output gear at the same time.

Note: When replacing the output gear check that the new component is of the correct ratio to match the drive pinions fitted.

- (v) Turn the gearbox over so the coupling is facing downwards and fit the spacer (item no. F8) onto the shaft.
- (vi) Press the front bearing onto the shaft and into the front bore.
- (vii) Refit the washer, lockstrip and two screws, ensuring that the screws are securely tabbed.

- (viii) Inspect the 'O' ring (item no. F2) which seals the front cover and replace if damaged. Refit the front cover.
- (ix) Refix the rear oil seal cover with four bolts.
- (x) Refit input shaft and layshaft assemblies as previously described.

9.8.2 Rear bearing and oil seal

- (i) Remove the output shaft assembly as described in section 9.7. The shaft will now be free complete with bearing, seal housing and output coupling.
- (ii) Unscrew the large locknut retaining the output coupling. Remove the washer and output coupling.
- (iii) Remove the rear housing with seal. If the seal is damaged, press out and replace.
- (iv) The bearing can now be removed from the shaft using a soft hammer or hand press.
- (v) If bearing is defective, check that the gears have not been damaged by debris. Similarly, if a gear is defective check that the bearing is undamaged.

9.9 Re-assembling the output shaft

- (i) Check that the large circlip (item no. F12) in the case bottom is undamaged. Renew if necessary.
- (ii) Remove the 'O' ring (item no. F16) and oil seal (item no. F15) from the rear housing and replace with new parts. (It is advisable to renew these parts whenever the output shaft is stripped).
- (iii) Press on rear bearing until it seats on the shoulder provided on the output shaft.
- (iv) Fit the rear cover, with 'O' ring and seal fitted to the output shaft.
- (v) Refit the output coupling, spacer and locknut. Tighten the locknut to 339Nm (250lbft, 34.6kgm).
- (vi) Complete reassembly as described in section 9.8.1 paras (iii) to (x).

9.10 Shimming procedures

The allowable end float on the taper bearing is 0-0.05mm (0-0.002in) clearance: this should be checked with the aid of a depth micrometer as follows:-

- (i) press the bearing outer cone firmly into position and measure between the face of the gearcase and the top of the bearing outer as shown in fig. 14.
- (ii) measure the depth of the recess in the oil pump and in the output shaft end cover. Make up the difference with shims.

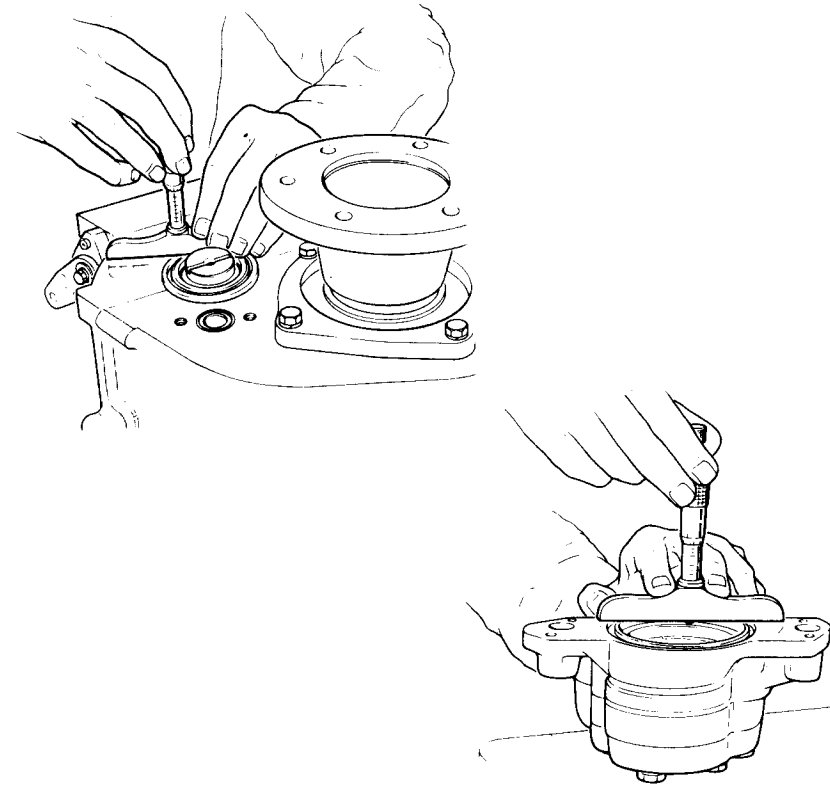

Fig. 14. shimming procedure

Where a depth micrometer is not available, the following method may be used:-

- (i) remove the 'O' ring from the oil pump or end cover;
- (ii) fit sufficient shims so that the oil pump or end cover stands proud of the gearbox.
- (iii) rotate the input shaft or layshaft whilst slowly tightening the four securing bolts until the shaft starts to bind. **Note: care must be taken to ensure that the oil pump or end cover is tightened squarely on to the gearbox face: this can be checked by feeler gauges or shims around the pump or end cover to ensure a uniform gap.**
- (iv) Now measure the gap with the aid of feeler gauges or shims. Deduct shims to this figure plus 0.050mm (0.002in) from the shims already installed.
- (v) Remove the necessary number of shims, tighten the oil pump or end cover, and test by rotating the shaft.
- (vi) Remove the oil pump or end cover and re-fit with the 'O' ring installed.

Note: shims are available in two thicknesses, 0.254mm (0.010in) and 0.05mm (0.002in). As an example of their use, if an end float reading of 0.548mm (0.023in) is obtained, two shims of 0.254mm (0.010in) and one of 0.05mm (0.002in) should be used, giving a final end float or clearance of 0.025mm (0.001in).

10. TIGHTENING TORQUES

	Nm	lbf.ft	kgfm
Upper to lower gearcase bolts	54.2	40	5.53
Valve block to upper gearcase	30.0	22	3.04
Operating lever to valve block	29.4	21.7	3.0
End cover to valve block (loctite)	9.5	7	0.97
Pump body to gearcase	54.2	40	5.53
End cover to gearcase	54.2	40	5.53
Pump cover to pump body	30.0	22	3.04
Coupling to output shaft	339.0	250	34.56

Top cover to upper gearcase	30.0	22	3.04
Oil seal housing to gearcase	54.2	40	5.53
Adaptor plate to gearbox	101.5	74.9	10.35
Output shaft bearing retaining plate (input end)	12.2	9	1.24
Clutch bolts	12.2	9	1.24

11. IDENTIFICATION PLATE

Every PRM gearbox is fitted with an identification plate on the top half of the gearcase before it leaves the factory; fig. 15 shows an example of such a plate.

Fig 15. identification plate	
Newage	Coventry
123456	A1234
310SVR3	
Use recommended lubricants only	

It will be noted that there are two lines of numbers.

The top line is the gearbox serial number, and should always be quoted when ordering spare parts; this enables the factory to trace the history of the gearbox right back to its date of manufacture and the components and materials used in its production, thus ensuring that the correct components can be supplied as spare parts.

The lower line is the gearbox specification; in the example given this translates as follows:-

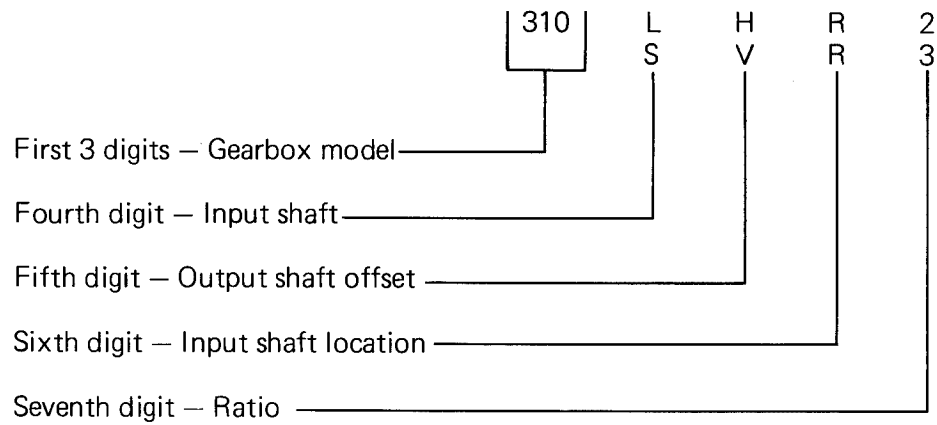

(PRM 310)

(S = standard, L = long)

(H = horizontal, V = vertical)

(R = right hand)

(2 = 1.96:1, 3 = 2.94:1)

SPARE PARTS ORDERING

When ordering spare parts the following should be quoted:

- (a) Gearbox model and serial number
- (b) Description(s) and part number(s) of the component(s) required
- (c) Quantity required

NOTES

- 1 Individual items which form part of an assembly, or main components, are indented and may be supplied separately; if the assembly is ordered all components pertaining to that assembly are supplied. For example, if the 'clutch input shaft' assembly is ordered the shaft itself and every item called up and shown on the corresponding illustration will be supplied, with the exception of the end housing and oil seal. The same applies to the layshaft.
- 2 Clutch plate assemblies, i.e. end plates, driven plates and driver plates are supplied in sets.

Orders and enquiries for spare parts should be addressed to:

**NEWAGE TRANSMISSIONS LIMITED
BARLOW ROAD
COVENTRY CV2 2LD
ENGLAND**

Tel: 0203 617141 Telex: 31333 Cables: 'SUPAGEARS' Coventry

METRIC DIMENSIONS

Where metric dimensions are shown in the description column, or without brackets in the remarks column, i.e. bearing dimensions, these are actual dimensions.

Where metric dimensions are shown within brackets in the remarks column, these are equivalent metric dimensions to imperial and are intended to assist identification of components only.

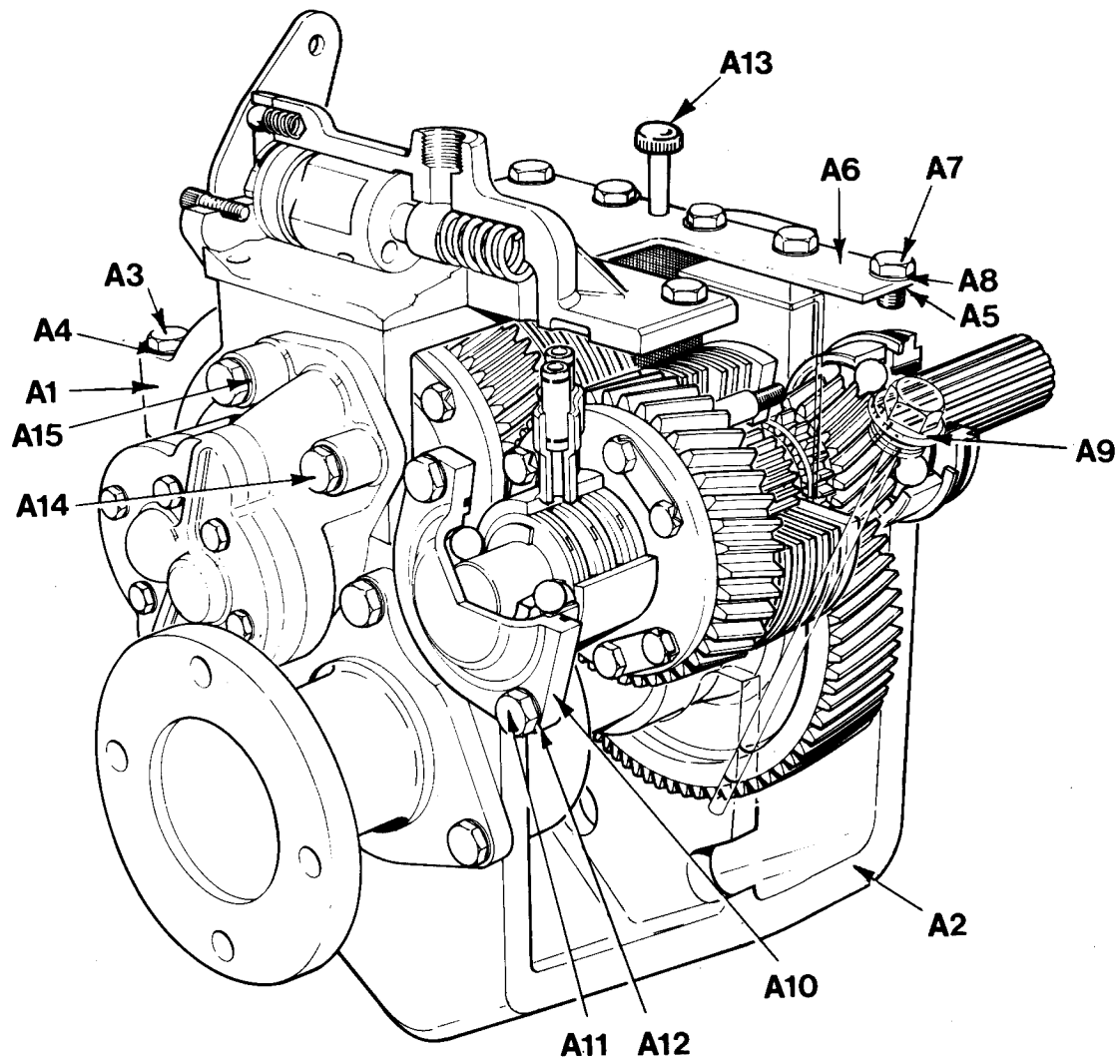

PLATE REF	DESCRIPTION	PRM310 PART NO.	Qty	REMARKS
A	Gearcase Assembly comprising			
	Case sub-assembly	MT0013	1	Supplied complete only
A1	Gearcase—top	MT992	1	Not supplied separately
A2	Gearcase—bottom	MT993	1	Not supplied separately
A3	Bolt	UBF113	6	3/8" x 2"
A4	Washer	W108	6	3/8"
A5	Gasket (topcover)	MT343	1	
A6	Top cover	MT743	1	
A7	Screw	USF12	10	5/16" x 1/2"
A8	Washer	CP1223	10	5/16"
A9	Dipstick	MT472	1	
A10	End cover	MT374	1	
A11	Screw	USF33	2	3/8" x 3/4"
A12	Washer	CP1224	2	3/8"
A13	Breather	CP1057	1	
A14	Bolt	UBF83	1	3/8" x 1.3/8"
A15	Washer	CP1224	4	3/8"
	Items not illustrated			
	Drain plug	CP1331	1	
	Washer dipstick/drain plug	CP1068	2	

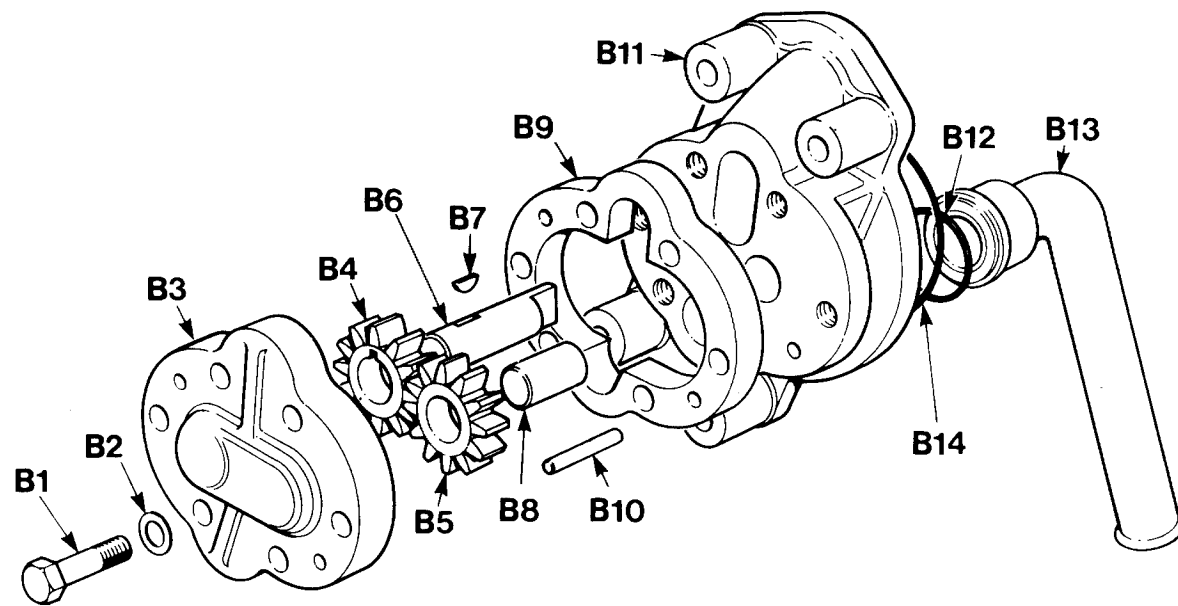

PLATE REF	DESCRIPTION	PRM310 PART NO.	Qty	REMARKS
B	Oil pump Assembly comprising	MT0010	1	
B1	Bolt	UBF92	6	5/16" x 1 1/2" 5/16" Dowty
B2	Washer	CP1223	6	
B3	Pump cover	MT321	1	
B4	Pump gear driver	MT377	1	
B5	Pump gear driven	MT379	1	
B6	Pump spindle	MT376	1	
B7	Spindle key	CP1089	1	
B8	Pump spindle	MT378	1	
B9	Pump plate	MT372	1	
B10	Dowel	MT417	2	
B11	Adaptor	MT1070	1	
B12	O ring	001254	2	
B13	Oil pipe	MT736	1	
B14	O ring	003383	1	

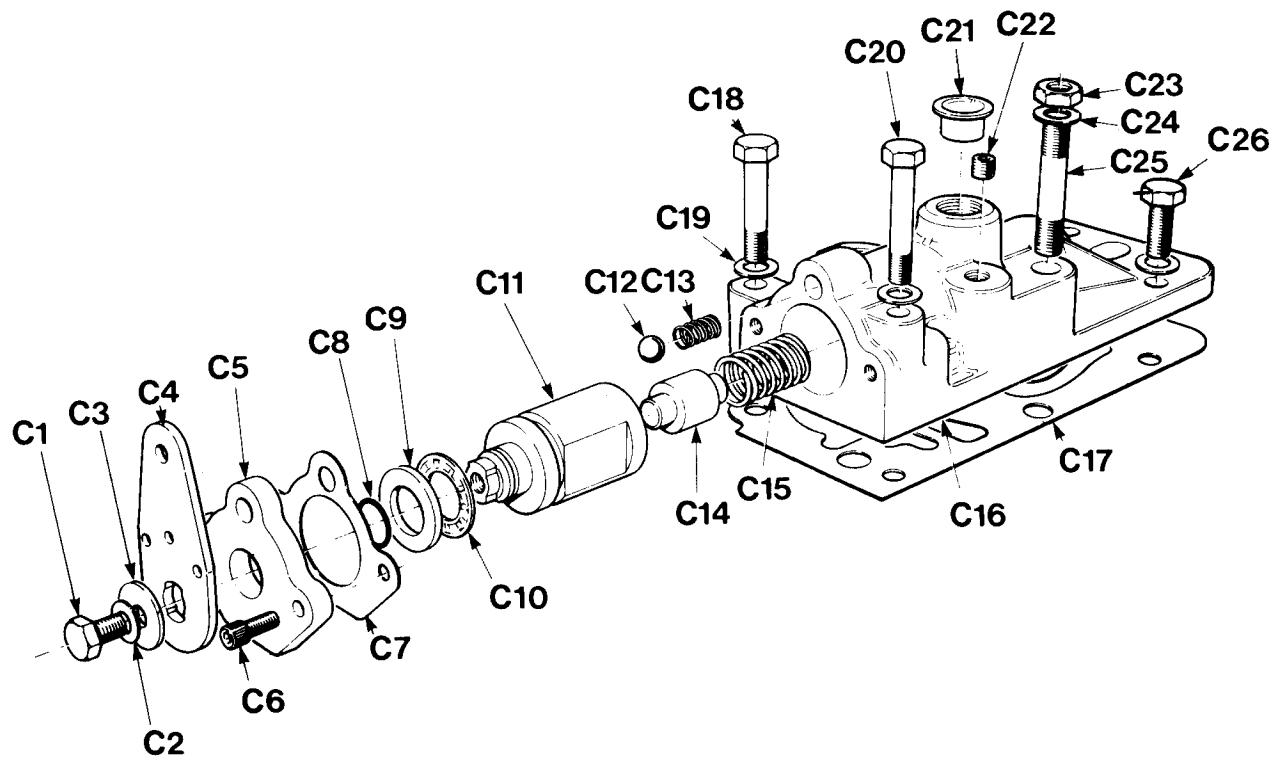

PLATE REF	DESCRIPTION	PRM310 PART NO.	Qty	REMARKS
C	Valve block Assembly comprising	MT0011	1	
C1	Screw	0040806	1	M8 x 16mm
C2	Spring washer	0191105	1	M8
C3	Washer	MT979	1	1"
C4	Operating lever	MT977	1	
C5	End plate	MT978	1	
C6	Cap screw	0081220	2	M5 x 20mm
C7	Gasket	MT1081	1	
C8	O ring	000753	1	
C9	Spacer	CP1308	1	
C10	Thrust bearing	CP1307	1	
C11	Control valve	MT976	1	
C12	Detent ball	CP1077	1	
C13	Detent spring	MT305	1	
C14	Relief valve	MT980	1	
C15	Valve spring	MT1194	1	
C16	Valve block	MT4600	1	
C21	Redcap seal	MT477	2	(Transit only)
C22	Pressure plug	MT311	1	3.17mm
C17	Gasket	MT1073	1	
C18	Bolt	UBF102	1	5/16" UNF x 1 3/4"
C19	Washer	CP1223	5	5/16"
C20	Bolt	UBF122	1	5/16" UNF x 2 1/4"
C23	Nut	UN505	1	3/8" UNF
C24	Washer	W108	1	3/8"
C25	Stud	MT1080	1	3/8" UNF x 5.11/16"
C26	Screw	USF52	3	5/16" UNF x 1"

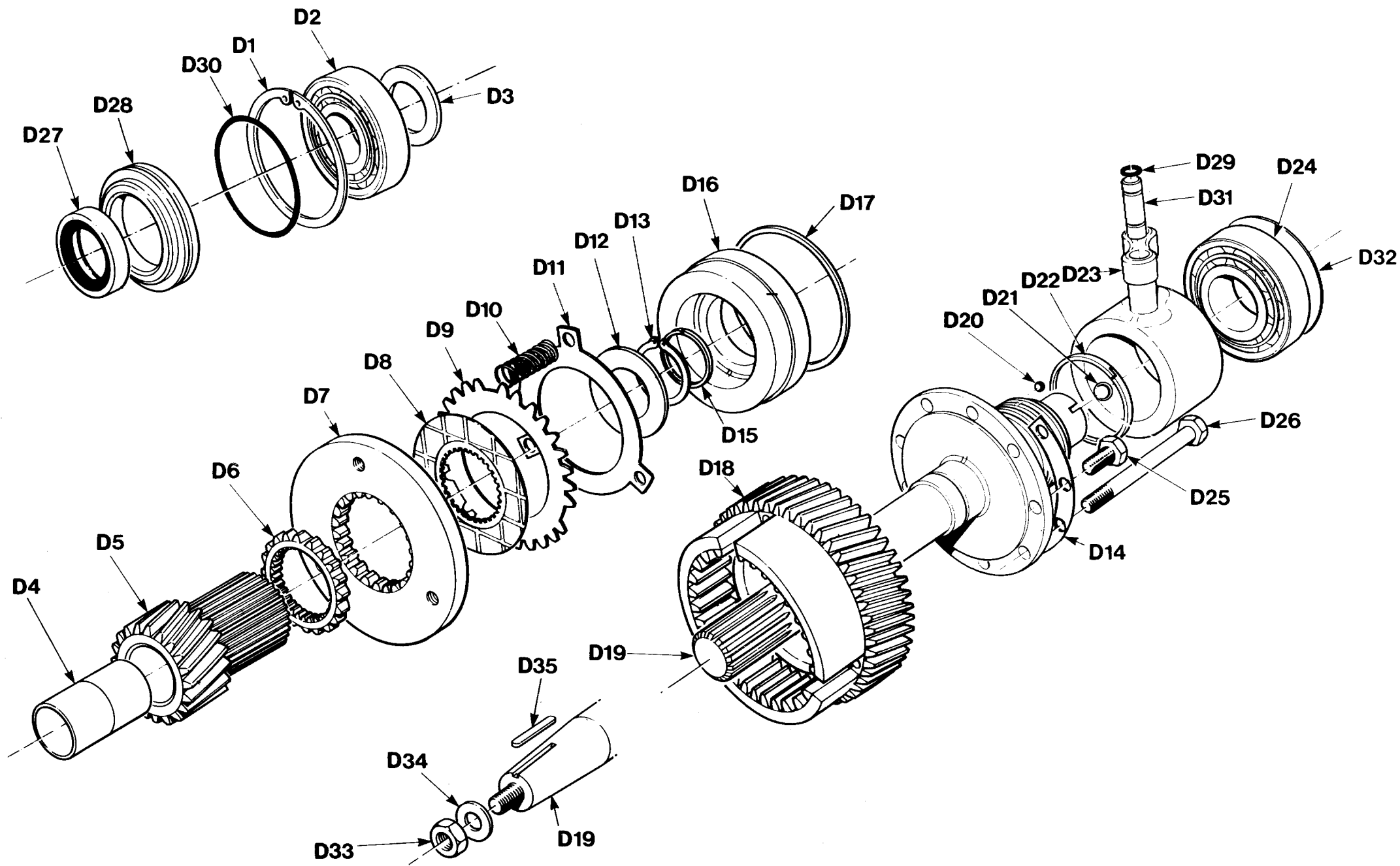

PLATE REF	DESCRIPTION	PRM310 PART NO.	Qty	REMARKS
D	Input shaft Assembly			
	Short splined shaft 1.5:1	MT0048/1.5	1)
	Short splined shaft 2:1	MT0048/2	1) Right hand rotation
	Short splined shaft 3:1	MT0048/3	1)
	Short splined shaft 1.5:1	MT0052/1.5	1)
	Short splined shaft 2:1	MT0052/2	1) Left hand rotation
	Short splined shaft 3:1	MT0052/3	1)
	Tapered shaft 1.5:1	MT0049/1.5	1)
	Tapered shaft 2:1	MT0049/2	1) Right hand rotation
	Tapered shaft 3:1	MT0049/3	1)
	Long splined shaft 1.5:1	MT0050/1.5	1)
	Long splined shaft 2:1	MT0050/2	1) Right hand rotation
	Long splined shaft 3:1	MT0050/3	1)
	Long splined shaft 1.5:1	MT0061/1.5	1)
	Long splined shaft 2:1	MT0061/2	1) Left hand rotation
	Long splined shaft 3:1	MT0061/3	1)
	Comprising:—			
D1	Circlip	CM2077	1	
D2	Taper roller bearing	0540301	1	
D3	Spacer	MT1090	1	
D4	Drive Pinion S/A	MT894	1	Supplied complete only
D5	Bush	MT416	2	Not supplied separately
	Pinion 1.5:1	MT892	1	37 teeth. Not supplied separately
D4	Drive Pinion S/A	MT740	1	Supplied complete only
D5	Bush	MT416	2	Not supplied separately
	Pinion 2:1	MT399	1	31 teeth. Not supplied separately
	Drive Pinion S/A	MT0093/3	1	Supplied complete only
D4	Bush	MT1139	1	Not supplied separately
D5	Pinion 3:1	MT1193	1	Not supplied separately

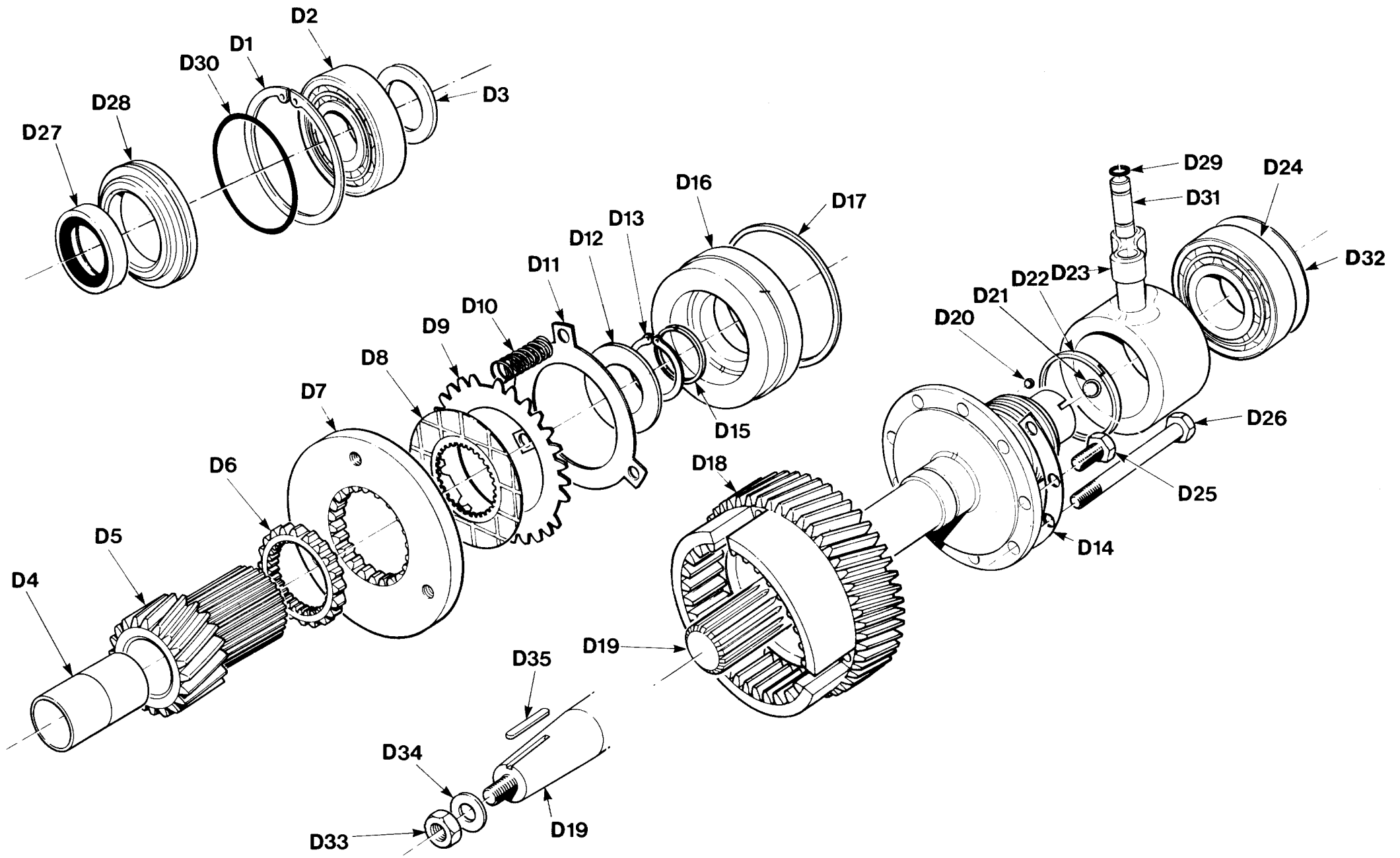

PLATE REF	DESCRIPTION	PRM310 PART NO.	Qty	REMARKS
D6	Emergency ring	MT395	1	
	Clutch pack	MT0064	1	
D7	Clutch end cover	MT994	1)
D8	Clutch plate driver	MT725	8)
D9	Clutch plate driven	MT982	7)
D10	Spring	MT1067	3) Not supplied separately
D11	End plate	MT983	1)
D12	Spacer	MT939	1)
D13	Circlip	0270350	1)
D14	Tab strip	MT1062	3)
D15	Piston ring	MT369	1	
D16	Piston	MT389	1	
D17	Piston ring	MT370	1	
D18	Clutch gear	MT989	1	
D19	Input shaft short spline	MT1130	1	
D19	Input shaft long spline	MT1132	1	
D19	Input shaft tapered	MT1131	1	
D20	Ball	CP1180	1	
D21	Ball	CP1191	1	
D22	Piston ring	MT292	3	
D23	Feeder	MT380	1	
D24	Taper roller bearing	0540351	1	
D25	Screw	0040607	12	M6 x 20mm
D26	Bolt	CP1321	3	M8 x 76.58mm
D27	Oil seal	MT251	1	
D28	End cover	MT1068	1	
D29	O ring	000372	4	
D30	O ring	002874	1	
D31	Connector	MT1057	2	
D32	Shim .002"	MT1077/02	AR	
D32	Shim .010"	MT1077/10	AR	
D32	Shim .031"	MT1077/31	AR	
D33	Nut	UN544	1)
D34	Washer	CP1288	1) Use with MT1131
D35	Key	MT761	1)

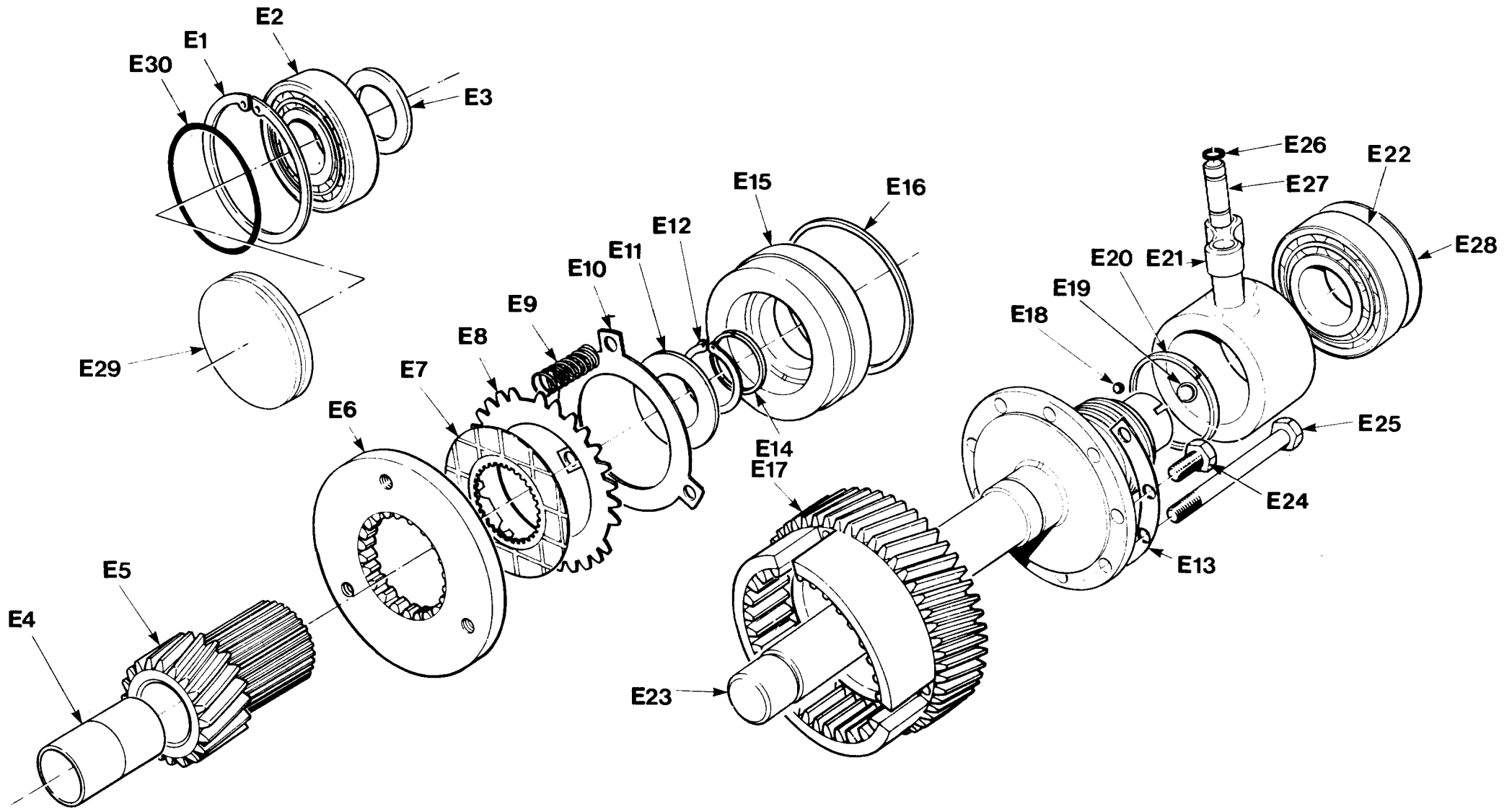

PLATE REF	DESCRIPTION	PRM310 PART NO.	Qty	REMARKS
E	Layshaft Assembly			
	Layshaft assembly 1.5:1	MT0047/1.5	1)
	Layshaft assembly 2:1	MT0047/2	1) Right hand rotation
	Layshaft assembly 3:1	MT0047/3	1)
	Layshaft assembly 1.5:1	MT0051/1.5	1)
	Layshaft assembly 2:1	MT0051/2	1) Left hand rotation
	Layshaft assembly 3:1	MT0051/3	1)
	Comprising:—			
E1	Circlip	CM2077	1	
E2	Taper bearing	0540301	1	
E3	Spacer	MT1090	1	
	Drive pinion S/A	MT894	1	Supplied complete only
E4	Bush	MT416	2	Not supplied separately
E5	Pinion 1.5:1	MT892	1	37 teeth. Not supplied separately
	Drive pinion S/A	MT740	1	Supplied complete only
E4	Bush	MT416	2	Not supplied separately
E5	Pinion 2:1	MT399	1	31 teeth. Not supplied separately
	Drive pinion S/A	MT0093/3	1	Supplied complete only
E4	Bush	MT1139	1	Not supplied separately
E5	Pinion 3:1	MT1193	1	Not supplied separately
	Clutch pack	MT0064	1	
E6	Clutch end cover	MT994	1)
E7	Clutch plate-driver	MT725	8)
E8	Clutch plate-driver	MT982	7)
E9	Spring	MT1067	3) Note supplied separately
E10	Clutch end plate	MT983	1)
E11	Spacer	MT939	1)
E12	Circlip	0270350	1)
E13	Tabstrip	MT1062	3)
E14	Piston ring	MT369	1	
E15	Piston	MT389	1	
E16	Piston ring	MT370	1	
E17	Clutch gear	MT969	1	
E18	Ball	CP1180	1	
E19	Ball	CP1191	1	

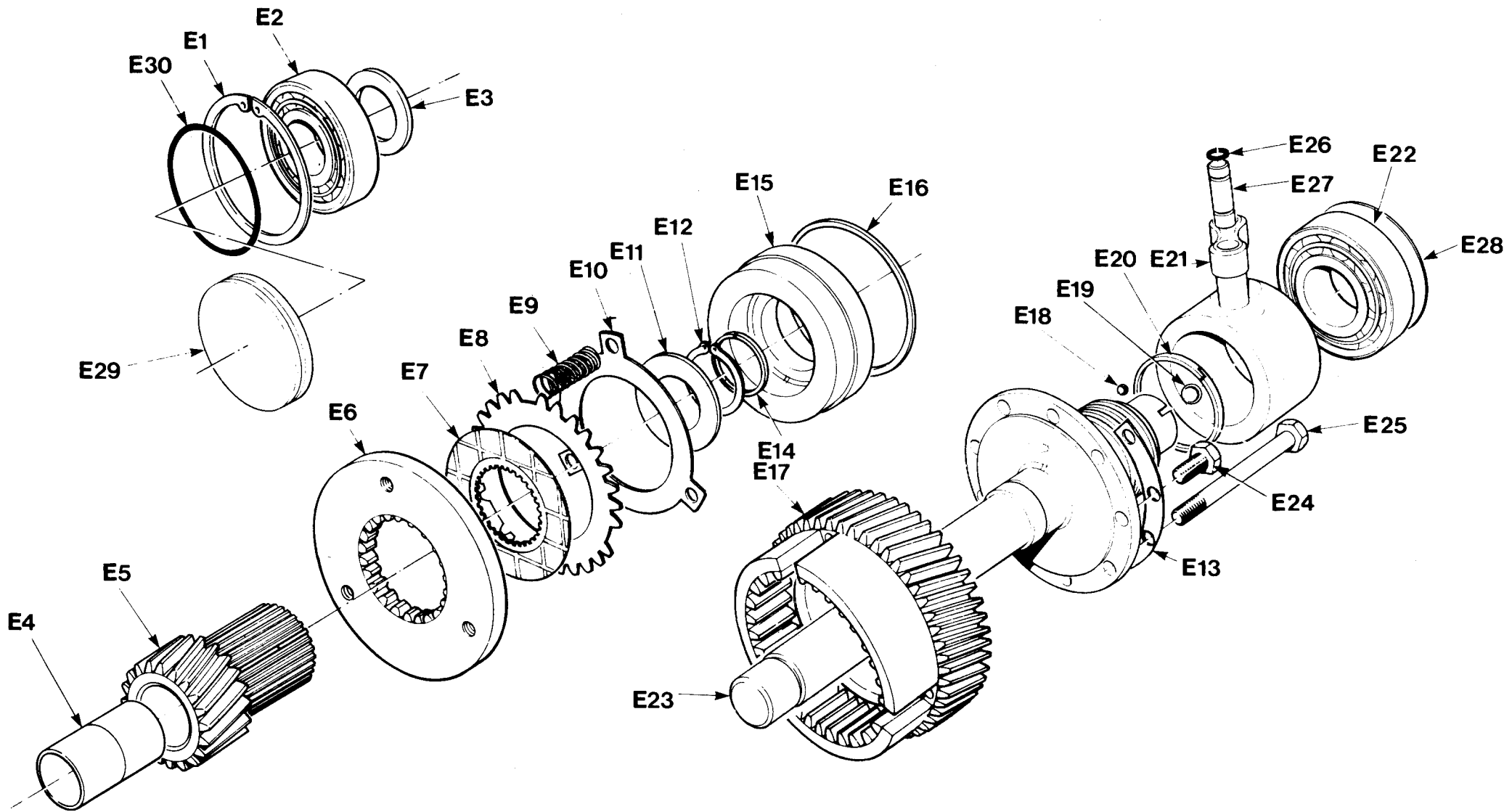

PLATE REF	DESCRIPTION	PRM310 PART NO.	Qty	REMARKS
E20	Piston ring	MT292	3	
E21	Feeder	MT380	1	
E22	Bearing	0540351	1	
E23	Layshaft	MT1129	1	
E24	Screw	0040507	12	M6 x 20mm
E25	Bolt	CP1321	3	M8 x 76.58mm
E26	O ring	000372	4	
E27	Connector	MT1057	2	
E28	Shim .002"	MT1077/02	AR	
E28	Shim .010"	MT1077/10	AR	
E28	Shim .031"	MT1077/31	AR	
E29	End cover	MT1069	1	
E30	O ring	002874	1	

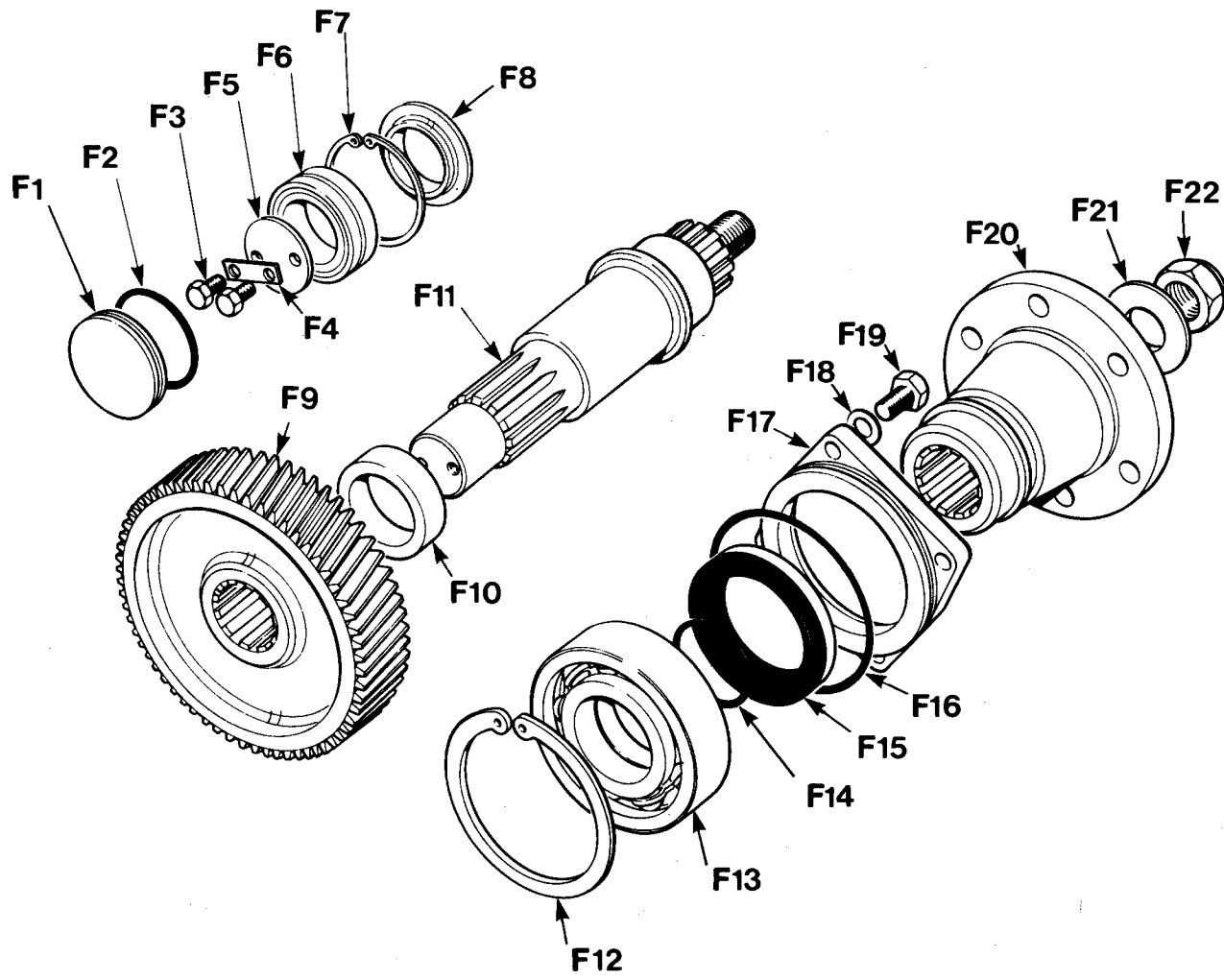

PLATE REF	DESCRIPTION	PRM310 PART NO.	Qty	REMARKS
F	Output shaft			
F1	End cover	MT985	1	
F2	O ring	002433	1	
F3	Screw	0040607	2	
F4	Lockstrip	MT986	1	
F5	Bearing washer	MT984	1	
F6	Needle bearing	0564001	1	
F7	Circlip	0250620	1	
F8	Spacer	MT987	1	
F9	Output gear 3:1	MT988	1	61 teeth
F9	Output gear 2:1	MT1063	1	60 teeth
F9	Output gear 1.5:1	MT1064	1	54 teeth
F10	Spacer	MT717	1	
F11	Output shaft	MT970	1	
F12	Circlip	CP1194	1	
F13	Ball bearing	MT451	1	
F14	O ring	002123	1	
F15	Oil seal	MT252	1	
F16	O ring	004754	1	
F17	End housing	MT375	1	
F18	Washer	W108	4	3/8"
F19	Bolt	USF63	4	3/8" x 1.1/8"
F20	Output flange	MT755	1	
F21	Washer	MT664	1	1"
F22	Locknut	MT690	1	1" UNF

Description	Part No.	Qty	Description	Part No.	Qty
O Ring Kit comprising:	MT0026		Strip and Inspection Kit	MT0111	
O ring feeder connector	000372	8	Tab strip	MT1062	6
O ring control valve	000753	1	Spring	MT1067	6
O ring oil pump	001254	2	O ring kit	MT0026	1
O ring output shaft	002123	1	Snap ring	0270350	2
O ring end cover	002874	2	Ratio change kit 1.5:1 ratio	MT0055	
O ring oil pump	003383	2	Pinion and bush S/A	MT894	2
O ring end cover	002433	1	Output gear	MT1064	1
O ring output shaft	004754	1	O ring kit	MT0026	1
Gasket valve block	MT1073	1	Ratio change kit 2:1 ratio	MT0054	
Gasket valve block end plate	MT1081	1	Pinion and bush S/A	MT740	2
Oil seal input shaft	MT251	1	Output gear	MT1063	1
Oil seal output shaft	MT252	1	O ring kit	MT0026	1
Gasket top cover	MT343	1	Ratio change kit 3:1 ratio	019613 MT0053	2
Clutch Pack	MT0064		Pinion and bush S/A	MT0093/3	1
Clutch plate driver	MT725	8	Output gear	MT988	1
Clutch plate driven	MT982	7	O ring kit	MT0026	1
Clutch end plate	MT983	1	Oil pump repair kit	MT904	
Spacer	MT939	1	Pump gear driver	MT377	1
Circlip	0270350	1	Pump gear driven	MT376	1
Spring	MT1067	3	Pump spindle	MT376	1
Tab washer	MT1062	3	Woodruff key	CP1089	1
Clutch end cover	MT994	1	Pump spindle	MT378	1
			Shimming kit	MT0068	
			Shim .002"	MT1077/02	6
			Shim .010"	MT1077/10	10
			Shim .031"	MT1077/31	