

**Volkswagen Marine
under full sails**

The Saildrive



Volkswagen Marine under full sails

We have never claimed that taking pleasure in Volkswagen Marine Power requires permanent use of it. It also feels good to have it aboard while being under sail.

Our engines have always been highly appreciated propulsion units for sail yachts, and not by coincidence. Their extremely low emissions, minimized maintenance requirements and their particularly refined running characteristics simply form an ideal package to meet the expectations of demanding sailing enthusiasts.

And one thing may be openly said, given the fact that we have many offshore sailing skippers in our own team: The engine of a cruising sailyacht is one of the most vital components of the boat, even if that is a difficult fact to admit for some of us ...

One look at today's typical coastal sailing reveals that bigger and bigger boats take to sea with very small crews or even single handled. That makes windward tacking a tough, if not marginal option in many situations, and it means at the same time that engines move far, far beyond their former use of merely driving a sail yacht into harbour if the wind lets you down.

Instead, they are often expected to push a boat through tough seas and strong winds. Volkswagen Marine diesel engines look forward to be at your service for this, even if you will hardly hear them in operation.



What we now offer is an adequate, state of the art saildrive option which is made by the leading player in this field, ZF Marine. In combination with that sturdy, reliable drive unit, our engines meet today's typical installation requirements aboard many, if not most sailing boats.

Being designed for combination with engines up to 55 kw (75hp), our saildrive will initially be offered in combination with our four cylinder series SDI 40-4, SDI 50-5 and SDI 60-4.

Along with our tailor-cut installation platform, the entire package can be installed by boatyards in a minimum of time and on a minimum of surface – yet offering all the qualities that have ensured a lot of attention for Volkswagen Marine from the beginning of our activity.

Fair winds to all who know how to use them!

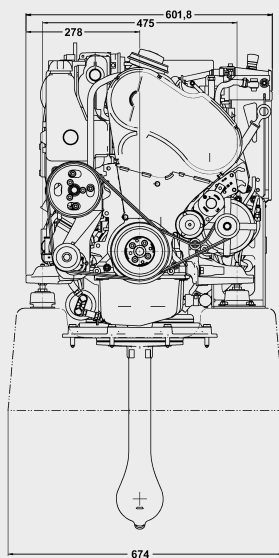
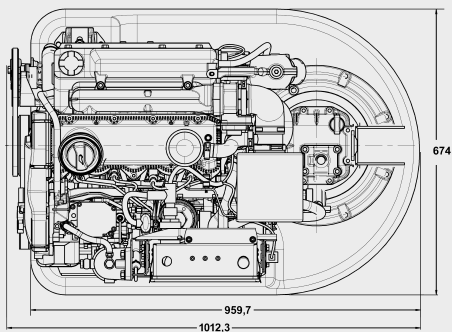
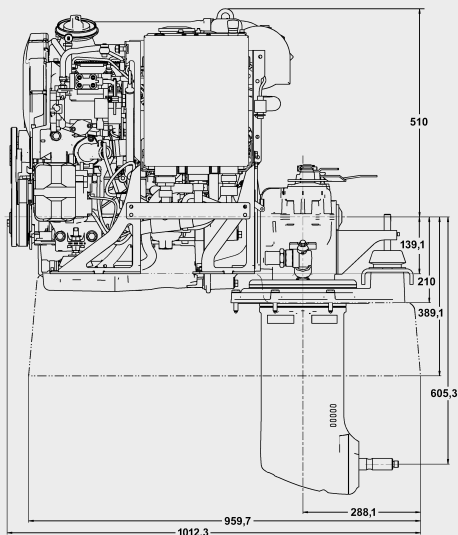

Specifications

Weight	33 kg (sailandrive unit excl. propeller)
Sealing System	Double rubber seal with water sensor
Oil change intervall	Annually or every 300 hours
Reduction ratios	2,16 and 2,52
Designed for max. performance of	55 kW (75 hp)

Subject to change without prior notice



VOLKSWAGEN
marine
 SUPERIOR TECHNOLOGY



Specifications	SDI 40-4 with saildrive unit	SDI 50-4 with saildrive unit	SDI 60-4 with saildrive unit
Engine type	4-cylinder Diesel	4-cylinder Diesel	4-cylinder Diesel
Fuel system	direct injection ¹	direct injection ¹	direct injection ¹
Cylinders	inline 4	inline 4	inline 4
Displacement [cm ³]	1.896	1.896	1.896
Stroke [mm]	95,5	95,5	95,5
Bore [mm]	79,5	79,5	79,5
Compression ratio	19,5:1	19,5:1	19,5:1
Performance (ISO 3046) [kW]	29	37	44
Performance [hp]	40	50	60
at	2.600 rpm	3.000 rpm	3.600 rpm
Specific power output [kW/l]	15,3	19,5	23,2
Appr. piston speed [m/s]	8,3	9,5	11,5
Max. torque [Nm]	125	125	125
at	2.000 rpm	2.000 rpm	2.000 rpm
Min. specific fuel consumption [g/kWh]	220	220	220
Weight [kg] ²	231	231	231
Alternator	90 A	90 A	90 A
Electrical system (2-polar)	12 V	12 V	12 V
Reduction Ratio Saildrive	2,16	2,16	2,52
Cooling	Thermostatically controlled double circuit cooling system with sea water/engine coolant heat exchangers, collective exhaust pipe, oil cooler, zink anode		
Other features	Connection for hot water preparation or heating optional		
Standard delivery includes	Wiring and instrumentation, on board computer, electric oil drain pump for oil change, engine mounts		

Subject to change without prior notice

¹ distribution injection pump

² dry weight incl. saildrive unit, excl. propeller & installation base



Volkswagen Marine
P.O. Box 31 11 76
D-38231 Salzgitter, Germany
Hotline (++) 18 01-89 89 00 (local call for Germany)

www.volkswagen-marine.com